



PRODUCT SELECTION DATA



- Energy Recovery
- Superior Reliability
- Energy Efficiency in Full and Part Load
- Serviceability / Flexible Design

Packaged Rooftop Units

Cooling Capacity 22-215 kW - Heating Capacity 24-229 kW

50/48 UC-(V)/UP-(V) 025-220





50/48 UC-(V)/UP-(V)
Packaged Rooftop Unit



Contents

General Features	4
Nomenclature	5
Ecodesign / Efficiency	5
Casing	7
Cooling Circuit / Compressor.....	7
Defrost Operation	7
Filter	7
EC Plug Supply Fan	8
Coils	8
Condenser Fan.....	8
Economizer.....	8
Serviceability	9
Control Panel.....	9
SmartVu™.....	10
Energy Meter	10
Compressor Softstarter	10
BMS Communication Boards	10
Room Thermostats	10
Zone Controller.....	10
Sensors	11
Dirty Filter Detection.....	11
Leak Detection.....	11
Additional Heating Options	
Electric Haeter.....	12
Hot Water Coil	12
Condensing Gas Heater.....	13
Electric Pre Heater	13
Energy Recovery Options	
Rotary Energy Recovery	13
Thermodynamic Energy Recovery (THR)	14
Power Exhaust Fan	15
Fire Safety Options.....	15
EC Plug Return Fan / Building Pressure Control.....	15
Air Duct Connection Options	16
Roofcurbs	16
Options	17
Accessories	20
Performance Tables	
Physical Data	21
Electrical Data	23
Min. & Max Air Flow Rates	24
Operating Limits	24
Sound Ratings.....	25
Dimensional Drawings.....	26
Supply Fan/ Return Fan / Power Exhaust Fan Tables	35
Pressure Drops	36
Electric Heater.....	39
Natural Gas Heater	40
Hot Water Coil Correction Factors By Temperature	44
Hot Water Coil Correction Factors By Liquied.....	45
Rotary Energy Recovery	46
Thermodynamic Energy Recovery	51
Product Guide Specifications	52



General Features

A rooftop is a unitary system installed outdoor and provides air conditioning of the room air through ducts with the ability to supply heating, cooling and ventilation in one concise unit.

With a total of 4 fixed speed compressors in 2 independent refrigerant circuit or optional inverter compressor, energy savings are enabled by reducing the power consumed of the units under partial load conditions. Additionally, EC plug fans used as standard at supply air side and return air side enable both efficiency and convenience when servicing. Thanks to EC plug fans, indoor pressurizing control is enabled with pressure control option.

New generation units can respond to any kind of duct connection direction requirement. Even if all the options at both supply and return air side are selected, bottom, top or side duct connection is possible.

At indoor unit side where air is conditioned, 30 mm double skin glass wool insulated panels are used as standard both for thermal performance and air leakage.

Alternative to DX coil heating in heat pump units, heating demand is met by multi stage electrical heater, proportional controlled hot water coil or condensing

high efficiency proportional controlled low NOx emission natural gas heaters, all integrated into the unit.

Rotary or thermodynamic energy recovery options can be selected. Thermodynamic energy recovery option includes a reversible cooling circuit inside the unit without allocating any space, therefore enables continuous energy recovery from return air, especially for the places where summer/winter seasons are moderate. For rotary energy recovery, an additional module can easily be installed on site and enables high capacity and high efficiency energy recovery for climates having severe summer/winter seasons.

Additionally, rotaries can be selected as both enthalpy and sorption type, therefore total energy to be recovered can be increased by utilizing both sensible and latent heat according to outside air humidity rate.

50/48 UC-(V)/UP-(V) rooftops are delivered with TSmartVu colour display human machine interface (HMI) as the other Carrier chillers. With this interface, user can access all the parameters of the unit, and through an Ethernet cable connected to the unit, can control the unit anywhere on the world over the Internet.



Nomenclature

Model Coding				
1-2	48	ROOFTOP SERIES	>	48: With Natural Gas Heater 50: Without Natural Gas Heater
3	U	HEAT REJECTION	>	U: Air Cooled
4	C	COOLING / HEATING	>	C: Cooling Only P: Heat Pump
5	V	COMPRESSOR	>	-: Fixed Speed V: Inverter
6-7-8	055	NOMINAL CAPACITY	>	025, 035, 045, 055, 065, 075, 090, 105, 125, 140, 160, 190, 220

Ecodesign / Efficiency

In accordance with the European Commission's 2016/2281 Regulation, rooftop units have begun to seek minimum seasonal efficiency criteria for both cooling and heating mode from the beginning of 2018.

These seasonal efficiency values, which are defined as SEER and SCOP, are calculated according to EN 14511 and EN 14825 standards.

The seasonal efficiency values calculated by taking into consideration the different capacity requirements of the units at different ambient air temperatures and the determined annual working hours of the units take

into consideration the power of the units not only in operation but also in the passive mode units such as standby and crankcase heater.

All 50/48 UC-(V)/UP-(V) new generation rooftop units' models have efficiency features over Ecodesign (EU 2016/2281) requirements, which will be valid in Europe in 2021.

Also 50/48 UC-(V)/UP-(V) Carrier rooftops are A class at all models in full load according to EN 14511-2018 standard. (EER, COP)*

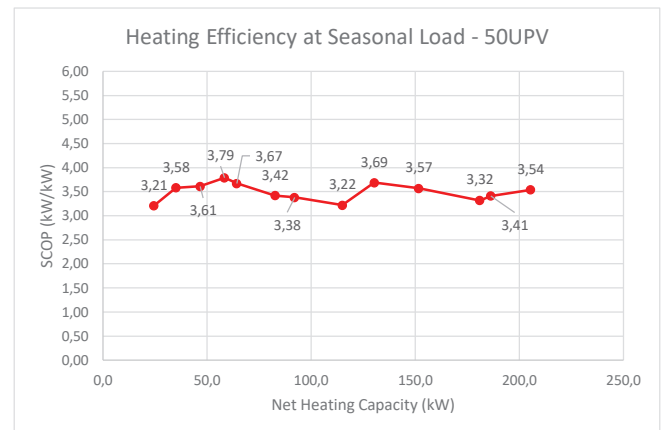
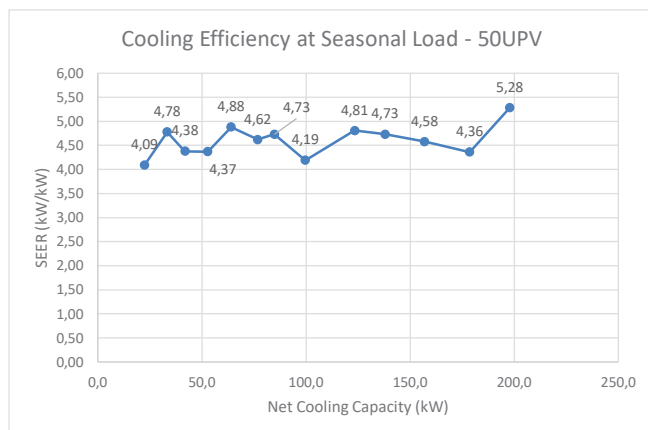
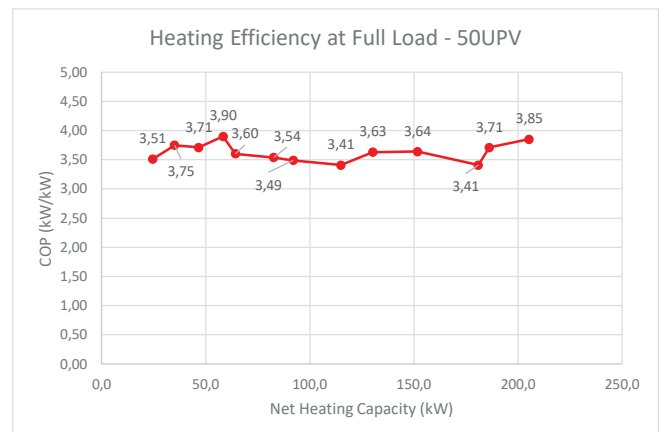
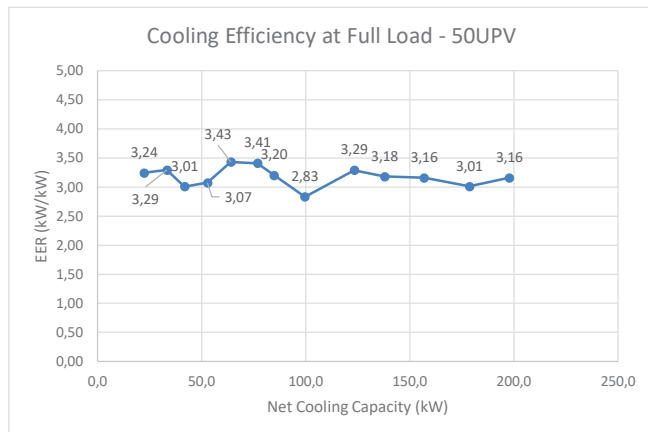

* Excluding 50/48 UP-105



50/48 UC-(V)/UP-(V)
Packaged Rooftop Unit

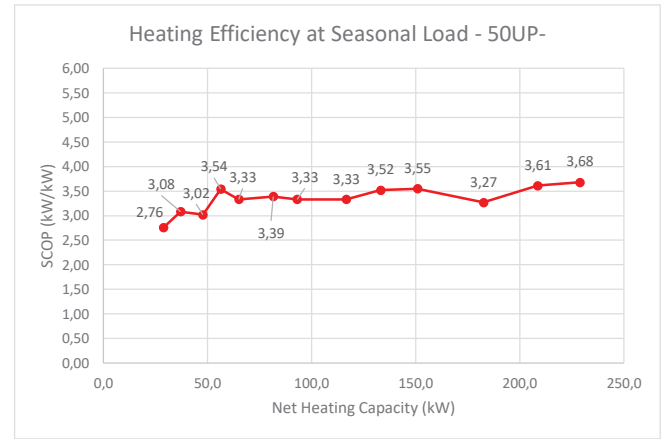
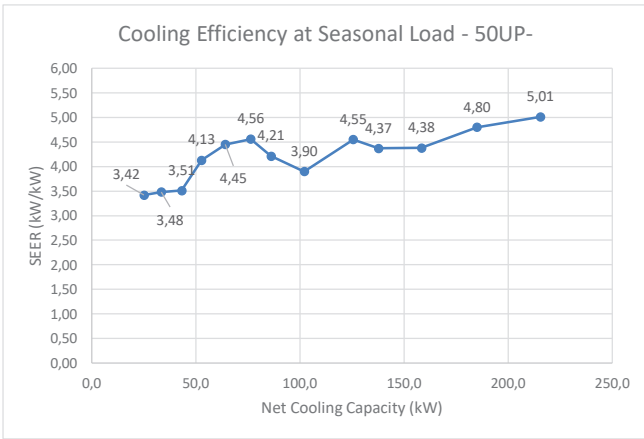
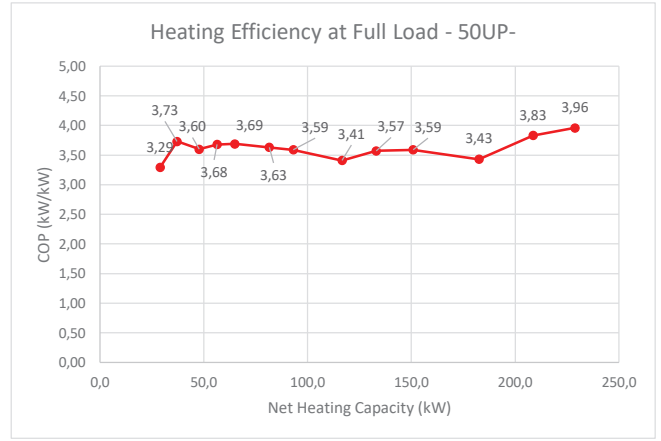
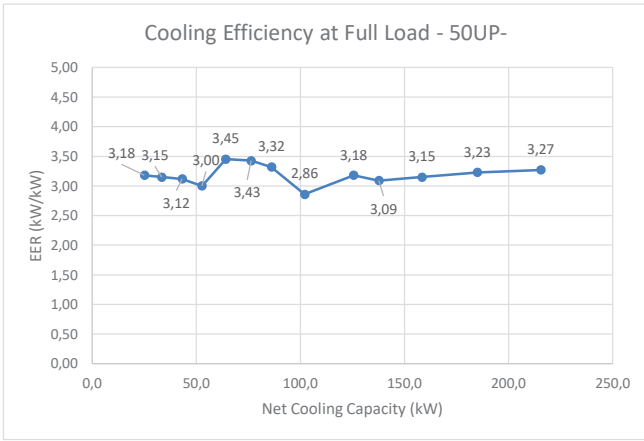

Casing

The -to the indoor unit- part of the unit have double skin sandwich panels having 30 mm thickness to minimize heat transfer between conditioned air and ambient air. Glass wool insulation is used in A1 fire class in sandwich panels. Outer panel sheet is polyester powder painted. All panels are removable for easy servicing.

Cooling Circuit / Compressors

Scroll compressors and R410A refrigerant are used in cooling circuit. In 50/48 UCV/UPV rooftops, 025-035-045-055 models have single circuit with one special high efficiency compressor with inverter technology and 065-075-090-105-125-140-160-190-230 models have two independent circuits, circuit A with one special high efficiency compressor with inverter technology and circuit B with tandem compressors. In 50/48 UC-/UP- rooftops, 025-035-045 models have single circuit with single fixed speed compressor, 055 model has single circuit with tandem compressors and 065-075-090-105-125-140-160-190-230 models have two independent circuits, each circuit have tandem compressors. In this way, all models have an efficiency higher than the seasonal efficiency values of Ecodesign 2021. By means of inverter compressors, it is possible to respond more precisely to variable load demands, preventing compressor on/off operation, thus increasing the reliability of the cooling system and ensuring longer operating life of the compressors.

The electronic expansion valve in the refrigerant circuit provides a more reliable and efficient control of the

refrigerant. Rubber support blocks are used under the compressors to prevent vibration and an electric crankcase heater are used on each compressor.

Defrost Operation

For heat pump units, when outdoor temperature is low in winter time, defrost operation are performed by an automatic adaptive algorithm taken from the controller to prevent frost on coils on the outdoor unit side. To prevent ice accumulation on the base of outdoor unit coil, base of coil is in a sloped structure for smooth drainage of water and an electrical heater is installed on the base.

Filter

Before the main thermodynamic coil, 50 mm wide cartridge framed G4 filters are used. The following filters are also available as an option.

- 50 mm, metal frame, G4 filter in M1 fire class
- 50 mm, metal frame, F7 filter in M1 fire class
- 50 + 50 mm, two-stage G4 + F7 filters with metal frame, M1 fire class
- 50 + 50 mm, two-stage M6 + F7 filters with metal frame, M1 fire class
- 50 + 50 mm two-stage F7 + F9 filters with metal frame, M1 fire class (50 + 96 mm for 125,140 and 160 model)

Optionally the unit can be equipped with a differential pressure switch which shall stop the unit and give an alarm when pressure drop in the filters reaches a predetermined value.





EC Plug Supply

Fan On the rooftop supply air side, EC plug fans are used as standard in IE4 motor efficiency class. In this view, the airflow rate is automatically reduced according to the demand, allowing the fans to draw less power and naturally achieve higher values in terms of seasonal efficiency. The wide operating range of the fans allows to meet all kinds of duct pressure losses and the room pressure can be maintained at the desired level thanks to the building pressure control option. Thanks to the EC plug fans, air flow rates can be monitored and changed at any time during start up and operating of the unit over SmartVu™.

The fans can be easily serviced by sliding mechanism out of the unit. The operation mode of the EC plug fans can be selected via controller in the constant air volume (CAV) mode to provide the desired air flow without being affected by the duct pressure drops on the critical line, or as the variable air volume (VAV) mode, which allows operation by considering the room temperature and the efficiency of the unit. There is a pressure sensor on the fans as a standard to stop the unit and give an alarm when it malfunctions.



Coils

Coils are formed by aluminium fins over internal grooved copper pipes. All coils are tested against leakage in a water pool under 30 bar pressurized air after manufacturing.

The interlaced (intertwined) structure of the indoor unit coils in the dual-circuit units allows for more reliable and efficient operation when only one circuit is operating.

In order to increase the UV and corrosion resistance, the aluminum fins in the indoor and / or outdoor unit coils can be coated with polyurethane on request.

A sloped drain pan made of minimum 304 grade stainless steel that can be dismantled through a sliding mechanism for easy servicing, with an insulated bottom is used under cooling coil.

A siphon with ball suitable for working at negative pressure for easy drainage of drain pan water is also supplied as standard with the unit.

Condenser Fan

Axial type, two-speed, Carrier-specific design Flying Bird™ VI generation fans are used which are made of composite material resistant to corrosion on the condenser side and working very quietly.

At partial load or low ambient temperatures, the fan automatically switches to low speed, the two-speed fan motor allows the fan speed to be adjusted for optimum efficiency.

Economizer

Economizer option consist of fresh air and return dampers and a motor perfectly matching each other to provide fresh air to operate the unit at requested conditions.

Fresh air damper in thermostatically controlled economizer is controlled by comparison with ambient and room temperature sensors.

In the enthalpy controlled economizer, fresh air damper is controlled by comparing with ambient, room temperature sensors and return and fresh air enthalpy sensors.

When the enthalpy economizer option is selected, ambient and return air enthalpy sensors are also supplied. Economizer is supplied with a hood to prevent ingress of rainwater and a bird screen to prevent objects.

Economizer can provide free cooling automatically through adjusting damper openings by the controller according to room cooling load requirement when outdoor air temperature is sufficiently low.

By controlling the outside air, indoor air and supply air temperature by means of SmartVu control, the economizer can make completely free cooling when necessary according to the required room cooling load, as well as free cooling with mechanical cooling with compressors when necessary.

Damper frames and fins are made of aluminium material and damper tightness classes are Class 2. Damper actuator is spring return type to close automatically in case of power failure or unit is turned off.

On request, a CO₂ sensor that can be mounted on the room can automatically adjust the damper openings by the controller to check the room air quality.

- The energy recovery module can be easily installed in the field.

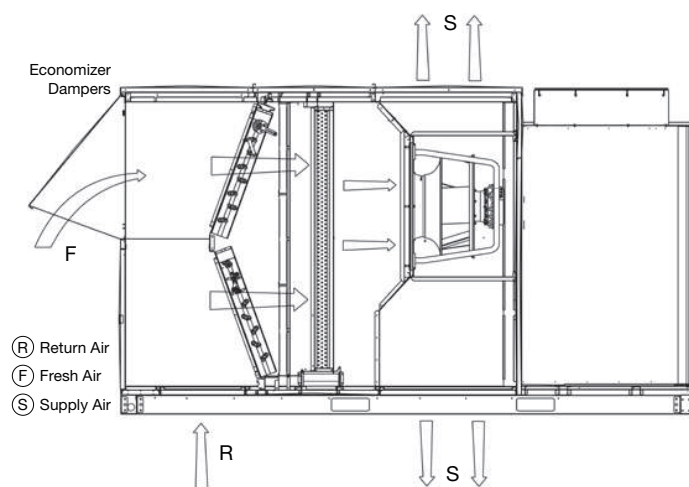

Control Panel

All cabling in the unit is made according to EN standards. A power switch is installed in control panel of the unit and for safety reasons panel door cannot not be opened until this switch is turned off.

Cables in the panel are colour coded and numbered. The unit is equipped with an IP68 protection class unions for all cable inlets and outlets.

The control panel of the unit has a relay for controlling the phase sequence and absence and a transformer for the 24 V control circuit.

The power supply of the unit (even with all options on it) is made from a single point.

Serviceability

- All the panels of UC-(V)/UP-(V) rooftops are removable and the internal components are easily accessible.
- Refrigeration cycle equipment and compressors are collected in an easily accessible area for easy serviceability.
- Since both the supply and return fans have a sliding mechanism, fans can be easily removed from the sliding mechanism when servicing.
- The drain pan under the cooling coil can be cleaned easily because it is removable.
- The power supply of the unit (even with all options on it) is made from a single point.
- The unit has standard a touch-sensitive colour display human machine interface (HMI) that allows access to all parameters.
- The cables on the control box are coloured and numbered.

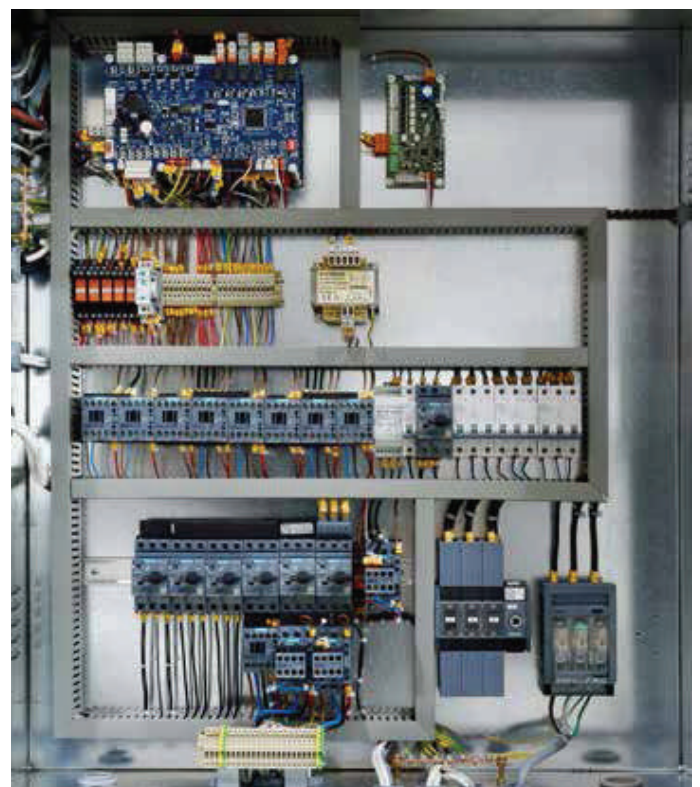



Energy Meter

The energy meter measures and displays minimum, maximum and total current, voltage and frequency for each phase and active & reactive power and power factor and total active & reactive



energy consumption in Wh. For mechanical and electrical connections of this option please refer to the certified wiring diagrams.

Compressor Softstarter

Softstarters expands lifespan of motors by protecting them from intense current. Compressor softstarter gradually increases the voltage to the compressor to have lower starting current.



For mechanical and electrical connections of this option please refer to the certified wiring diagrams.

SmartVu™

The controller of the unit, SmartVu™, optimizes energy efficiency by continuously controlling the refrigeration cycle and all other functions and options of the unit to provide thermal comfort. A non-volatile memory, microprocessor controlled touch-screen 4.3" human machine interface (HMI), with pictogram to access all parameters of the unit and control it is installed on each unit as standard for ease of use. This human machine interface (HMI) is in IP 65 protection class and have a cover to protect it from external impacts. The controller has different language options. Units with SmartVu control can be easily accessed from anywhere in the world using a PC with an Ethernet connection. In this way, significant advantages are provided for remote quick and easy control and service operations.



With the advanced control algorithm, a total of 76 different alarms can be detected. An alarm that may occur in the unit can be sent to a predetermined e-mail address.

Some of the other features provided by the unit's advanced software are as follows:

- weekly / daily / hourly programming
- holiday mode
- control from two room sensors
- thermal shock prevention
- master/slave control for up to 6 units
- sequential or delayed start
- night mode of operation
- purge mode
- smart start

BMS Communication Boards

BACnet IP and Modbus RTU or TCP/IP protocols are standard with SmartVu control.

Room Thermostat

A programmable or non-programmable room thermostat with an LCD display can be provided to control the unit from room (on/off, temperature control, mode selection, etc.).



Zone Controller

Zone controller with LCD display allows the unit to be controlled from the room. It allows all functions including on / off, alarm display & reset, user, service & factory configuration, setpoint setting, etc.)

Sensors

Ambient, supply duct and room temperature sensors (T55) are supplied as standard for controlling the room thermal conditions with rooftop unit. Optionally, the temperature information for the operation of the unit can be made by means of the duct sensor which will be placed in the return duct rather than the room. In addition, the unit can be controlled according to temperature detection from two different points. When two sensors are selected, the set temperature can be adjusted via the controller, the average of the two sensors, the maximum and minimum values of the incoming data in heating or cooling.

• **Room sensor T55:** The sensor which is placed in the room and temperature information is sent to the unit. It includes an override function of the occupied mode. (Standard)



• **Room sensor T56:** The sensor which is placed in the room and temperature information is sent to the unit. It includes an override function of the occupied mode and temperature setting function of $\pm 3^{\circ}\text{C}$ (with 1 K intervals). (optional)



• **Room sensor T59:** The sensor which is placed in the room and temperature information is sent to the unit. It includes an override function of the occupied mode, temperature setting function of $\pm 3^{\circ}\text{C}$ (with 0.5 K intervals), on / off function and LCD display. (optional)



• **Indoor Air Quality Sensor CO₂:** In addition to the room temperature sensors, the control of the room air quality can also be controlled by the CO₂ sensor for units with economizer option. (optional)



• **Return duct sensor:** Return duct temperature sensor. The operation of the unit is based on the temperature information received from the return duct, not from the room. (optional)



Dirty Filter Detection

Dirty filter detection is controlled from the SmartVu control via the input from the differential pressure switch checking the pressure drop across the filter. The factory setting is 250 Pa and it is adjustable. If the pressure drop across the filter exceeds 250 Pa, there will be an alarm on the SmartVu control and the necessary actions will be taken. For mechanical and electrical connections of this option please refer to the certified drawings and wiring diagrams, and to the SmartVu Control IOM for further information.

Leak Detection

When the refrigerant is detected by a refrigerant leak detector located after the indoor coil, before the indoor fan of the unit, the controller of the unit gives an alarm and unit is shut down.





Additional Heating Options

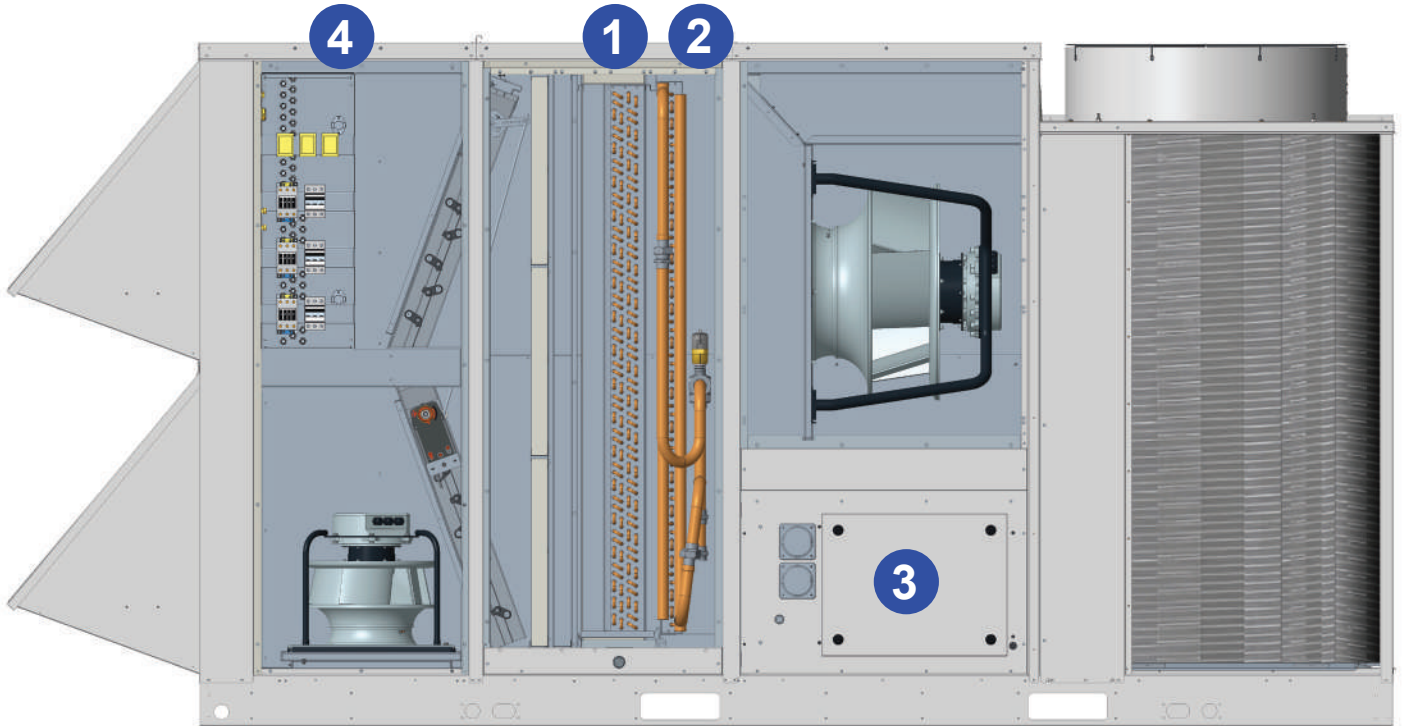

1) Electric Heater

The electrical heater is placed after the main thermodynamic coil, before the supply fan, and allows the desired temperature for room comfort in the winter season.

Electrical heaters can be selected as low, medium and high heat type according to the unit model. Depending on the option type, it operates as 2 or 3 stage controlled.

The electrical heaters are mounted into the unit and tested in the factory. Electrical heaters have a total of four temperature limit switches which two of them can be reset manually and the other two can be reset automatically.

During the frost protection (defrost) operation of the heat pump units, the electrical heaters are activated automatically.

In heat pump units, electrical heaters are switched on after the compressors have run 100% and when ambient air fall below a threshold that can be set from controller.

2) Hot Water Coil

Hot water coil is placed after the main thermodynamic coil, before the supply fan, and allows the desired temperature for room comfort in the winter season. The temperature of the supply air is controlled by proportional capacity control (100% modulating control with 0-10 V signal) with three-way valve in hot water coil. There are service valves at the inlet and outlet of the hot water coil. Hot water coil is mounted into the unit and tested in the factory. During the frost protection operation of the heat pump units, the hot water coil becomes activated automatically. There is a frost protection thermostat on the hot water coil. According to the signal coming from this thermostat, in case of frost, 3-way valve is automatically opened and all the water is passed from the coil. In heat pump units, after the compressors operate 100% hot water coil is activated or the compressor is deactivated from the controller and only the hot water coil is charged with the thermal load.

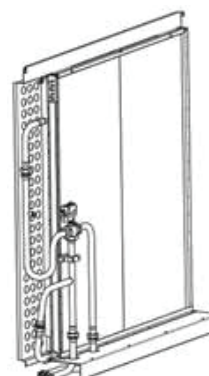
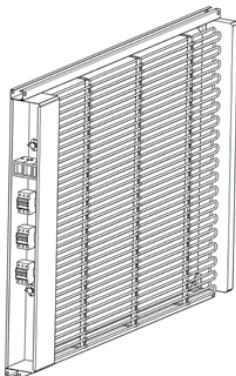

3) Condensing Natural Gas Heater

Condensing Natural Gas Heater is placed after the main thermodynamic coil and the supply fan, and allows the desired temperature for room comfort in the winter season. Natural gas heaters can be selected in 2 or 3 different thermal capacities (low, medium and high) according to the unit model. In the natural gas heater, the capacity control is proportional between 22-100% and the efficiency of natural gas consumption is adjusted according to the heating need. Natural gas heaters can operate at temperatures down to -20 °C. Also burning efficiency up to 109%, condensing technology and proportional control provides both precise comfort and efficiency. Microprocessor based electronic board regulates heat outlet and controls fan and gas valve for air/gas mixture. Carbon monoxide emission of premix burner is zero (CO=0), and NOx emission is very low (NOx < 30 ppm- Class 5) and complies with ErP regulations. With its combustion chamber, heat exchanger, premix burner where air and gas gets mixed, natural gas heater is provided as a package with CE certificate from the manufacturer.

2009/142/CE, 2006/42/CE, 2006/95/CE, 2004/108/CE). Combustion chamber and complete heat exchanger is made of AISI 441 stainless steel, providing long service life and reliability.

For safety reasons, natural gas heater are equipped with a manual reset safety thermostat, ignition and flame detection electrodes, flame ionization control unit and electronic ignition unit for the burner. In heat pump units, the user can set any

of them as main or auxiliary heater through natural gas heating via controller or without compressor with heat pump mode.



4) Electric Pre-Heater

The electric pre-heater is placed before the economizer fresh air damper to pre-heat fresh air depending on outdoor air conditions. Shielded electric resistance heaters are fully factory-wired and tested. Each stage is protected against

overloads by two thermal protectors. The low-limit protector with automatic overload protection and is set to 90°C. It is located less than 150 mm after electric heaters. Refer to the certified drawings and wiring diagrams for the electric heaters and to the SmartVu Control IOM for further information.

Energy Recovery Options

Rotary Energy Recovery (ERM) It is a high efficiency rotary energy recovery that allows the exhaust air to be recovered by transferring the energy to the fresh air. The rotary type energy recovery types are the most efficient energy recovery systems. In particular, it is much more advantageous than other energy recovery systems when the temperature difference between the ambient air and the exhaust air is high and fresh air is more used. The size of the energy recovery rotary is large enough to operate with 100% fresh air. It can also be selected as an enthalpy or sorption type in different types according to outdoor weather conditions, allowing maximum energy recovery.

Sorption type rotary are effective for more energy recovery by drawing from the latent heat of outside air, especially in areas with high humidity. The used energy recovery rotary has Eurovent certification. The site setup of the energy recovery module is quite simple. The main unit and the power supply of the ERM are made from the single point on the unit. There is an additional G4 filter to protect the rotary in the fresh air inlet. On the fresh air side of the energy recovery module, the part between the rotary and the unit is 30 mm insulated and double-skinned.





Thermodynamic Energy Recovery (THR)

Thermodynamic energy recovery is an additional independent refrigerant circuit energy recovery system that includes a DX coils on the exhaust and supply air side, a compressor and an expansion valve to recover energy by transferring the energy from exhaust air to the supply air. It is more advantageous than other energy recovery systems, especially at seasonal passages and by providing stable energy recovery at times when the temperature difference

between room and ambient air is not too high. Fresh air ratio can be 20-100% in THR mode. As the energy recovery system is integrated into the unit, the unit dimensions do not increase. Depending on the amount of fresh air used, 25% to 40% of the unit capacity is provided with energy recovery. The advanced controller can operate in accordance with the free cooling mode depending on the room load requirement.

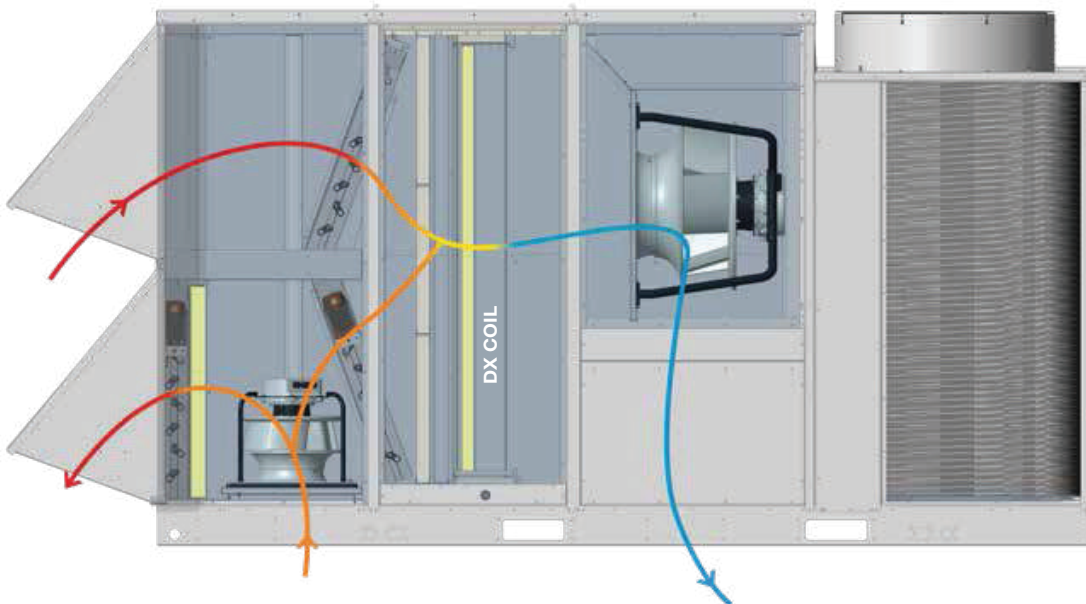

Power Exhaust Fan

The power exhaust fan allows pressurization of the exhaust air in the medium pressure loss return duct and helps to reduce the positive pressure as the amount of fresh air at the room increases. When the fresh air intake in the unit exceeds a certain value (Factory setting, 50%) it becomes active. At the same time, the power exhaust fan, which also includes a barometric exhaust damper, has an axial fan running at a constant speed.

- (R) Return Air
- (S) Supply Air
- (F) Fresh Air
- (E) Exhaust air

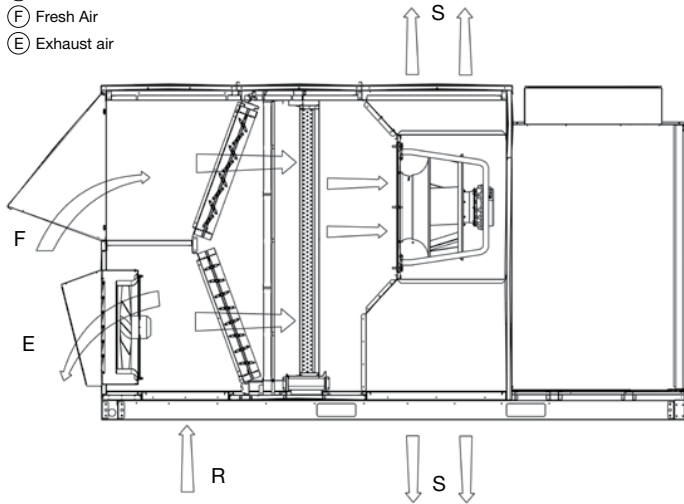

Fire Safety Options

An optional smoke detector on the return air side of the unit closes the return damper when smoke is detected, opens the fresh air damper and stops the supply fan to help evacuate the smoke out of the room.

EC Plug Return Fan and Building Pressure Control

Optionally, on the return side of the unit, EC plug type fans can be selected in IE4 motor efficiency class. The return fans work in series with the supply air fan, helping to compensate for the total pressure drop in the air duct. The return fans can be easily serviced by sliding mechanism out of the unit. Thanks to the EC plug fans, air flow rates can be monitored and changed at any time during start up and operating of the unit over SmartVu™. In addition to the return fan option, there is an additional damper on the exhaust side of the unit for exhausting the excess air created by the use of fresh air. With the return fan option, a pressure balance is automatically provided in the room with the air flow rates determined during the project phase. In addition to the return fan, the building pressure control option can also be selected and the pressure inside the building can be adjusted via the controller by means of the room pressure sensor, so that it can be kept at a desired positive or negative value much more precisely.





Air Duct Connections Options

Carrier new generation rooftops are designed to meet all types of user requirements for air duct inlet and outlet connections. The flexible design allows air duct connection to the units in three different ways on both the supply and return air side.

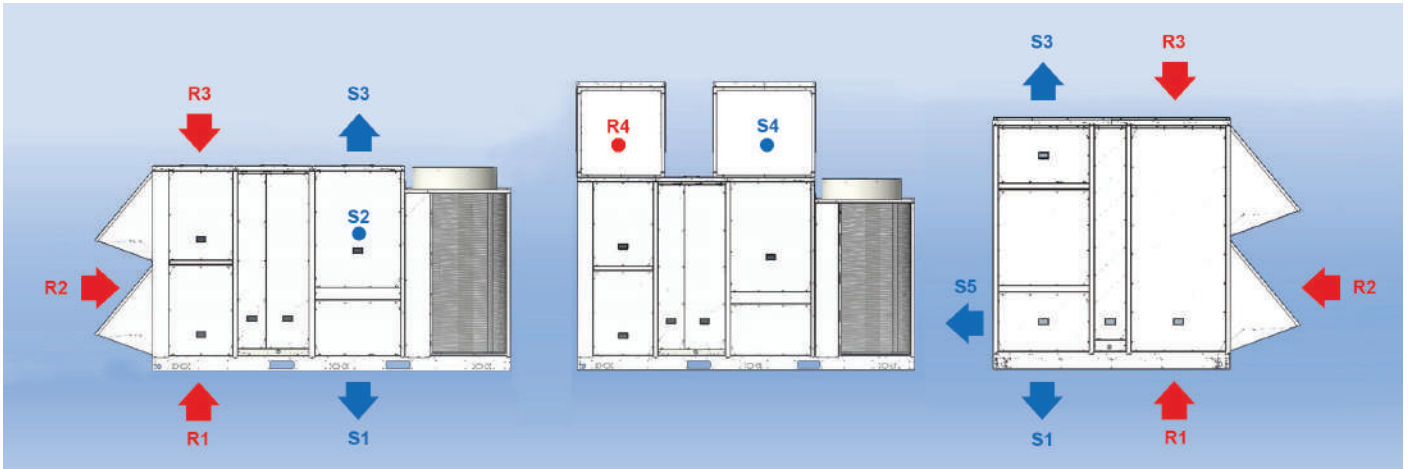

Supply				
Reference	Option No	Duct Connection Way	With Natural Gas Heater	Without Natural Gas Heater
S1	Standard	Bottom Supply	Yes	Yes
S2	231	Side Supply	No	Yes
S3	232	Top Supply	Yes	Yes
S4*	233	Side Supply via Top Plenum	Yes	Yes
S5	234	Face (Rear) Supply	No	Yes

Return						
Reference	Option No	Duct Connection Way	Economizer	Return Fan	Thermodynamic HR	Rotary HR
R1	Standard	Bottom Return	Yes	Yes	Yes	Yes
R2	241	Face (Front) Return	Yes	No	No	No
R3	242	Top Return	Yes	Yes	Yes	Yes
R4*	243	Side Return via Top Plenum	Yes	Yes	Yes	Yes
-	-	-	-	-	-	-

Roofcurb

Under the rooftop a roofcurb can be provided which has a construction that carries the weight of the unit, is insulated, serves as a base between the unit and the air duct and provides ease of installation. For energy recovery (ERM) units, a roofcurb can also be provided, covering the ERM module base.

Vertical roofcurb

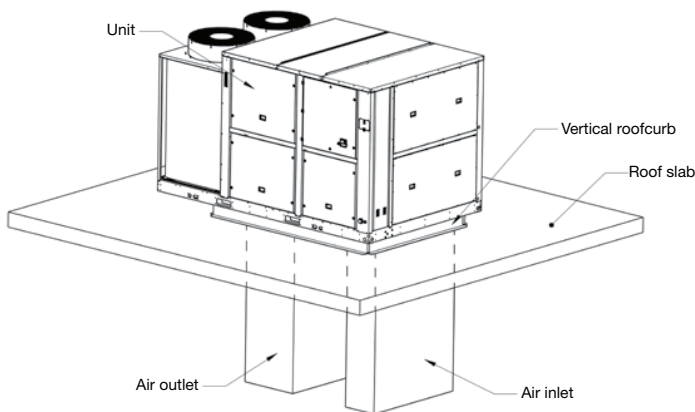

ERM E / S and 48 / 50 UP / UC with vertical Roofcurb

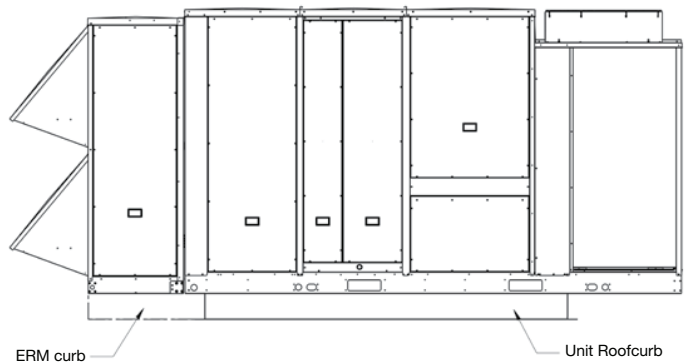



Options

Option Name	Option No	Option Description	025	035	045	055	065	075	090	105	125	140	160	190	220	Not Compatible Option / Accessory	Mandatory Option / Accessory must be used together
Electric Heater																	
Electric Heater (Low Heat before Supply Fan)	121	The electric heater is placed after the main thermodynamic coil, before the supply fan and allows for the desired temperature for indoor comfort during the winter season.			X	X	X	X	X	X						124, 125, 126, 127, 128, Thermostat, 1211, 1221, 1231, 146, 147, 148, 149	
Electric Heater (Medium Heat before Supply Fan)	122		X	X	X	X	X	X	X	X							
Electric Heater (High Heat before Supply Fan)	123		X	X	X	X	X	X	X	X							
Electric Heater (Low Heat after Supply Fan)	1211	The electric heater is placed after the main thermodynamic coil and the supply fan and allows for the desired temperature for indoor comfort during the winter season.									X	X	X	X	X	121, 122, 123, 124, 125, 126, 127, 128, 129, Thermostat, 231 146, 147, 148, 149	
Electric Heater (Medium Heat after Supply Fan)	1221										X	X	X	X	X		
Electric Heater (High Heat after Supply Fan)	1231										X	X	X	X	X		
Hot Water Coil																	
Hot Water Coil (Low Heat after Supply Fan)	124	The hot water coil is placed after the main thermodynamic coil and the supply fan and allows for the desired temperature for indoor comfort during the winter season.									X	X	X	X	X	121, 122, 123, 125, 126, 127, 128, 129, 1211, 1221, 1231, Thermostat, 231	
Hot Water Coil (High Heat before Supply Fan)	125	The hot water coil is placed after the main thermodynamic coil, before the supply and allows for the desired temperature for indoor comfort during the winter season.	X	X	X	X	X	X	X	X						121, 122, 123, 124, 126, 127, 128, 129, 1211, 1221, 1231, Thermostat	
Hot Water Coil (High Heat after Supply Fan)	129	The hot water coil is placed after the main thermodynamic coil and the supply fan and allows for the desired temperature for indoor comfort during the winter season.									X	X	X	X	X	121, 122, 123, 124, 125, 126, 127, 128, 1211, 1221, 1231, Thermostat, 231	
Natural Gas Heater																	
Condensign Natural Gas Heater - Modulating (Low Heat)	126	The condensing natural gas heater is placed after the main thermodynamic coil and the supply fan and allows the desired temperature for indoor comfort in the winter season.	X	X	X	X	X	X	X	X	X	X	X	X	X	121, 122, 123, 124, 125, 129, Thermostat, 231, 1211, 1221, 1231	
Condensign Natural Gas Heater - Modulating (Medium Heat)	127		X	X	X	X	X	X	X	X	X	X	X	X	X		
Condensign Natural Gas Heater - Modulating (High Heat)	128						X	X	X	X	X	X	X				
Coil Coating																	
Outdoor Coil, Precoated Fin - Copper Tube	131	Aluminum coil fins are coated with polyurethane to increase corrosion and UV resistance.	X	X	X	X	X	X	X	X	X	X	X	X	X		
Outdoor and Indoor Coil, Precoated Fin - Copper Tube	132		X	X	X	X	X	X	X	X	X	X	X	X	X		
Indoor Coil, Precoated Fin - Copper Tube	133		X	X	X	X	X	X	X	X	X	X	X	X	X		
Outdoor Air Options																	
Manual Outdoor Air Damper	141	A manually adjustable damper provides fresh air intake. Supplied with a hood and wire cage.	X	X	X	X	X	X	X	X	X	X	X	X	X	142, 143, 146, 147, 148, 149 172, 174, 175, 176, 177, 182, 183, 184, 221, 222, 223	
Economizer - Thermostatic Control	142	The economizer option consists of two fresh air and return dampers and a motor that are compatible with each other to obtain fresh air ratio at the desired operating conditions of the unit. The economizer is controlled by comparing it with the room and ambient temperature sensors. Supplied with a hood and wire cage.	X	X	X	X	X	X	X	X	X	X	X	X	X		
Economizer - Enthalpic Control	143	The economizer option consists of two fresh air and return dampers and a motor that are compatible with each other to obtain fresh air ratio at the desired operating conditions of the unit. The economizer is controlled by comparing it with the room, ambient temperature, return duct and fresh air enthalpic sensors. Supplied with a hood and wire cage.	X	X	X	X	X	X	X	X	X	X	X	X	X		
Economizer - Thermostatic + Pre-Heater_Low	146	The electric pre-heater is placed before the economizer fresh air damper and the main thermodynamic coil and allows pre-heating fresh air depending on outdoor air conditions in order to maintain the required min. coil entering air temperature for heating mode.	X	X	X	X	X	X	X	X	X	X	X	X	X	172, 174, 176, 177	
Economizer - Thermostatic + Pre-Heater_High	147		X	X	X	X	X	X	X	X	X	X	X	X	X		
Economizer - Enthalpic + Pre-Heater_Low	148		X	X	X	X	X	X	X	X	X	X	X	X	X		
Economizer - Enthalpic + Pre-Heater_High	149		X	X	X	X	X	X	X	X	X	X	X	X	X		
Supply Fan																	
EC Plug Supply Fan - High Static Pressure	151	EC plug fan capable of providing higher external static to meet the high pressure losses in the air duct.							X	X	X	X	X	X	X		
Filter																	
G4 Filter (M1 Fire Class)	161	Before main thermodynamic coil, metal frame, 50 mm wide, M1 fire class, G4 filter	X	X	X	X	X	X	X	X	X	X	X	X	X		
F7 Filter (M1 Fire Class)	162	Before main thermodynamic coil, metal frame, 50 mm wide, M1 fire class, F7 filter	X	X	X	X	X	X	X	X	X	X	X	X	X		
G4 + F7 Filter (M1 Fire Class)	163	Before main thermodynamic coil, metal frame, 50 + 50 mm wide, M1 fire class, two stage G4 + G7 filters	X	X	X	X	X	X	X	X	X	X	X	X	X		
M6 + F7 Filter (M1 Fire Class)	164	Before main thermodynamic coil, metal frame, 50 + 50 mm wide, M1 fire class, two stage M6 + G7 filters	X	X	X	X	X	X	X	X	X	X	X	X	X		
F7 + F9 Filter (M1 Fire Class)	165	Before main thermodynamic coil, metal frame, 50 + 50 mm wide, M1 fire class, two stage F7 + F9 filters (50 + 96 mm for 125, 140 and 160 model)	X	X	X	X	X	X	X	X	X	X	X	X	X		



50/48 UC-(V)/UP-(V)
Packaged Rooftop Unit

Option Name	Option No	Option Description	025	035	045	055	065	075	090	105	125	140	160	190	220	Not Compatible Option / Accessory	Mandatory Option / Accessory must be used together
Energy Recovery																	
Energy Recovery - Enthalpic - Medium	172	The energy recovery module with enthalpy type rotary the pre-conditioning of fresh air upto 100% nominal supply airflow by utilizing the energy of the exhaust air. There is a G4 filter on the fresh air side of the energy recovery module.	X	X	X	X	X	X	X	X	X	X	X	X	X	174, 175, 181, 182, 241, 176, 177	142 or 143 or 146 or 147 or 148 or 149; 183 or 184
Energy Recovery - Sorption - Medium	174	The energy recovery module with sorption type rotary the pre-conditioning of fresh air upto 100% nominal supply airflow by utilizing the energy of the exhaust air. There is a G4 filter on the fresh air side of the energy recovery module.	X	X	X	X	X	X	X	X	X	X	X	X	X	172, 175, 181, 182, 241, 176, 177	142 or 143 or 146 or 147 or 148 or 149; 183 or 184
Thermodynamic Energy Recovery	175	It is an additional independent refrigerant circuit heat recovery system that includes a DX coils on the exhaust and supply air side, a compressor and an expansion valve to recover energy by transferring the energy from exhaust air to the supply air.	X	X	X	X	X	X	X	X	X	X	X			172, 174, 181, 182, 241, 176, 177	142 or 143 or 146 or 147 or 148 or 149; 183 or 184
Energy Recovery - Enthalpic - Large	176	The energy recovery module with enthalpy type rotary the pre-conditioning of fresh air upto 100% max. supply airflow by utilizing the energy of the exhaust air. There is a G4 filter on the fresh air side of the energy recovery module.	X	X	X	X	X	X	X	X	X	X	X	X	X	172, 174, 175, 181, 182, 241, 177	142 or 143 or 146 or 147 or 148 or 149; 183 or 184
Energy Recovery - Sorption - Large	177	The energy recovery module with sorption type rotary the pre-conditioning of fresh air upto 100% max. supply airflow by utilizing the energy of the exhaust air. There is a G4 filter on the fresh air side of the energy recovery module.	X	X	X	X	X	X	X	X	X	X	X	X	X	172, 174, 175, 181, 182, 241, 176	142 or 143 or 146 or 147 or 148 or 149; 183 or 184
Return / Exhaust Air Options																	
Barometric Exhaust Damper	181	Barometric exhaust option consisting of gravity-closure aluminum blades located on the exhaust side of the unit, allowing the excess positive pressure in the space to be evacuated and protecting the exhaust side of the appliance from.	X	X	X	X	X	X	X	X	X	X	X	X	X	172, 174, 175, 182, 183, 184, 241, 176, 177	141 or 142 or 143 or 146 or 147 or 148 or 149
Power Exhaust Fan - Axial	182	It is an axial type exhaust fan running at a fixed speed located on the exhaust side of the unit, which allows the excess positive pressure to be evacuated in the room when the fresh air ratio reaches a certain value.	X	X	X	X	X	X	X	X	X	X	X	X	X	141, 172, 174, 175, 181, 183, 184, 241, 176, 177	142 or 143 or 146 or 147 or 148 or 149
EC Plug Return Fan	183	EC plug return fan operates in series with the supply fan, mounted on the return side of the unit, which helps to cover total air duct pressure losses.	X	X	X	X	X	X	X	X	X	X	X	X	X	141, 181, 182, 184, 241	142 or 143 or 146 or 147 or 148 or 149
EC Plug Return Fan and Building Pressure Control	184	EC plug return fan operates in series with the supply fan, mounted on the return side of the unit, which helps to cover total air duct pressure losses and building pressure control option which provides the desired positive / negative pressure value in the room with a room pressure sensor.	X	X	X	X	X	X	X	X	X	X	X	X	X	141, 181, 182, 183, 241	142 or 143 or 146 or 147 or 148 or 149
Temperature Sensor																	
T56 Temperature Sensor	191	It is a room temperature sensor by adjusting room temperature ± 3 °C and extend occupied mode with override function.	X	X	X	X	X	X	X	X	X	X	X	X	X	192, 193, 194, 195	
T59 Temperature Sensor	192	It is a room temperature sensor by adjusting room temperature ± 3 °C, extend occupied mode with override function, LCD display and on/off button.	X	X	X	X	X	X	X	X	X	X	X	X	X	191, 193, 194, 195	
T55 + T56 Temperature Sensors	193	T55 and T59 sensors supplied together.	X	X	X	X	X	X	X	X	X	X	X	X	X	191, 192, 194, 195	
T55 + T59 Temperature Sensors	194	T56 and T59 sensors supplied together.	X	X	X	X	X	X	X	X	X	X	X	X	X	191, 192, 193, 195	
Return Duct Temperature Sensor	195	Unit operates according to temperature information obtained from the return duct not from room.	X	X	X	X	X	X	X	X	X	X	X	X	X	191, 192, 193, 194	
Energy Management Options																	
Compressor Softstarter	212	Compressor softstarter gradually increases the voltage to the compressor to have lower starting current.	X	X	X	X	X	X	X	X	X	X	X	X	X		50/48UC-/UP- 50/48UCV/UPV
Energy Meter	213	The energy meter measures and displays minimum, maximum and total current, voltage and frequency for each phase and active & reactive power and power factor and total active & reactive energy consumption.	X	X	X	X	X	X	X	X	X	X	X	X	X		
Compressor Softstarter + Energy meter	214	Compressor Softstarter and Energy meter are supplied together.	X	X	X	X	X	X	X	X	X	X	X	X	X		50/48UC-/UP- 50/48UCV/UPV



Option Name	Option No	Option Description	025	035	045	055	065	075	090	105	125	140	160	190	220	Not Compatible Option / Accessory	Mandatory Option / Accessory must be used together
Fire Safety Options																	
Smoke Detector	221	When the smoke is detected by a smoke detector located on the return air side of the unit, the return damper is closed and the fresh air damper is fully opened and the supply fan is stopped to evacuate the smoke from the room.	X	X	X	X	X	X	X	X	X	X	X	X	X	141, 222, 223	142 or 143 or 146 or 147 or 148 or 149
Fire Thermostat	222	When the set high temperature detected by a fire thermostat located on the return air side of the unit, the return damper is closed and the fresh air damper is fully opened and the supply fan is stopped to evacuate the smoke from the room.	X	X	X	X	X	X	X	X	X	X	X	X	X	141, 221, 222	142 or 143 or 146 or 147 or 148 or 149
Smoke Detector + Fire Thermostat	223	Smoke detector and fire thermostat are supplied together.	X	X	X	X	X	X	X	X	X	X	X	X	X	141, 221, 223	142 or 143 or 146 or 147 or 148 or 149
Supply Duct Connection Options																	
Bottom Supply	230	It is an opening at the bottom of the unit for duct connection to the supply air.	X	X	X	X	X	X	X	X	X	X	X	X	X	231, 232, 233, 234	
Side Supply	231	It is an opening at the side of the unit for duct connection to the supply air.	X	X	X	X	X	X	X	X	X	X	X			126, 127, 128, 230, 232, 233, 234, Roofcurb	
Top Supply	232	It is an opening at the top of the unit for duct connection to the supply air.	X	X	X	X	X	X	X	X	X	X	X	X	X	230, 231, 233, 234, Roofcurb	
Side Supply via Top Plenum	233	It is an opening at the side of the unit via top plenum for duct connection to the supply air.	X	X	X	X	X	X	X	X	X	X	X	X	X	230, 231, 232, 234, Roofcurb	
Face (Rear) Supply	234	It is an opening at the rear face of the unit for duct connection to the supply air.												X	X	230, 231, 232, 233, Roofcurb	
Return Duct Connection Options																	
Bottom Return	240	It is an opening at the bottom of the unit for duct connection to the return air.	X	X	X	X	X	X	X	X	X	X	X	X	X	241, 242, 243	
Face (Front) Return	241	It is an opening at the front face of the unit for duct connection to the return air.	X	X	X	X	X	X	X	X	X	X	X	X	X	172, 174, 175, 181, 182, 183, 184, 240, 242, 243, Roofcurb	
Top Return	242	It is an opening at the top of the unit for duct connection to the return air.	X	X	X	X	X	X	X	X	X	X	X	X	X	240, 241, 243, Roofcurb	
Side Return via Top Plenum	243	It is an opening at the side of the unit via top plenum for duct connection to the return air.	X	X	X	X	X	X	X	X	X	X	X	X	X	240, 241, 242, Roofcurb	
Packing																	
Pallet + Coil Protection + Plastic Wrap	251	This packaging option consists of a pallet under the unit, a cardboard protection covering the outdoor coils and a nylon wrapping around the entire unit.	X	X	X	X	X	X	X	X	X	X	X	X	X	252, 253, 254, 255	
70 % Open Crate + Coil Protection + Plastic Wrap	252	This packaging option consists of a 70% open wooden crate, a cardboard protection covering the outdoor coils and a nylon wrapping around the entire unit.	X	X	X	X	X	X	X	X	X	X	X	X	X	251, 253, 254, 255	
Outdoor Coil Protection Grill + Plastic Wrap	253	This packaging option consists of a protection grill covering the outdoor coils and a nylon wrapping around the entire unit.	X	X	X	X	X	X	X	X	X	X	X	X	X	251, 252, 254, 255	
Pallet + Outdoor Coil Protection Grill + Plastic Wrap	254	This packaging option consists of a pallet under the unit, a protection grill covering the outdoor coils and a nylon wrapping around the entire unit.	X	X	X	X	X	X	X	X	X	X	X	X	X	251, 252, 253, 255	
70 % Open Crate + Outdoor Coil Protection Grill + Plastic Wrap	255	This packaging option consists of a 70% open wooden crate, a protection grill covering the outdoor coils and a nylon wrapping around the entire unit.	X	X	X	X	X	X	X	X	X	X	X	X	X	251, 252, 253, 254	



Accessories

Accessory Name	Accessory No	Accessory Description	025	035	045	055	065	075	090	105	125	140	160	190	220	Not Compatible Option / Accessory	Mandatory Option / Accessory must be used together	
Roofcurb																		
Vertical Roofcurb	57250113201	Under the rooftop, it is a roofcurb option which acts as a base between the unit and the air duct to provide ease of installation.	X	X	X	X										231, 232, 233, 234 241, 242, 243		
	57250113202						X	X	X	X							231, 232, 233, 234 241, 242, 243	
	57250113203										X	X					231, 232, 233, 234 241, 242, 243	
	57250141101												X				231, 232, 233, 234 241, 242, 243	
	57350024220													X	X		231, 232, 233, 234 241, 242, 243	
Vertical Roofcurb with ERM-Medium	57270117001	Under the rooftop, (covering unit and ERM module base) it is a roofcurb option which acts as a base between the unit and the air duct to provide ease of installation.	X	X												231, 232, 233, 234 241, 242, 243	172, 174	
	57270117002				X	X										231, 232, 233, 234 241, 242, 243	172, 174	
	57270117003						X	X	X	X						231, 232, 233, 234 241, 242, 243	172, 174	
	57270117005										X	X				231, 232, 233, 234 241, 242, 243	172, 174	
	57270117006												X			231, 232, 233, 234 241, 242, 243	172, 174	
	57250160106													X	X		231, 232, 233, 234 241, 242, 243	172, 174
Vertical Roofcurb with ERM-Large	57270117001	Under the rooftop, (covering unit and ERM module base) it is a roofcurb option which acts as a base between the unit and the air duct to provide ease of installation.	X	X												231, 232, 233, 234 241, 242, 243	176, 177	
	57270117002				X											231, 232, 233, 234 241, 242, 243	176, 177	
	57270117004					X										231, 232, 233, 234 241, 242, 243	176, 177	
	57270117003						X	X								231, 232, 233, 234 241, 242, 243	176, 177	
	57270117005								X	X						231, 232, 233, 234 241, 242, 243	176, 177	
	57270117006										X					231, 232, 233, 234 241, 242, 243	176, 177	
	57270117007											X	X			231, 232, 233, 234 241, 242, 243	176, 177	
	57250160107													X	X		231, 232, 233, 234 241, 242, 243	176, 177
Room Controls																		
Programmable Room Thermostat	57260040001	Programmable room thermostat with LCD display that allows the unit to be controlled from the room.					X	X	X		X	X	X	X	X	121, 122, 123, 124, 125, 126, 127, 128, 129, 1211, 1221, 1231		
Non-programmable Room Thermostat	57260040002	Non-programmable room thermostat with LCD display that allows the unit to be controlled from the room.					X	X	X		X	X	X	X	X	121, 122, 123, 124, 125, 126, 127, 128, 129, 1211, 1221, 1231		
Zone Controller 33PILOT-01	65020050150	Zone controller with LCD display allows the unit to be controlled from the room. It allows all functions including on / off, alarm display & reset, user, service & factory configuration, setpoint setting, etc.)	X	X	X	X	X	X	X	X	X	X	X	X	X			
Compressor Insulation																		
Compressor Blanket	57280112001	It is an isolation of the compressor to prevent freezing of oil in cold weather.	X														50/48UCV/UPV	
	57280112002			X													50/48UCV/UPV	
	57280112003				X												50/48UCV/UPV	
	57280112004					X											50/48UCV/UPV	
	57280112006			X	X												50/48UC-/UP-	
	57280112007					X											50/48UC-/UP-	
	57280112008						X										50/48UC-/UP-	
	57280112005							X	X	X							50/48UC-/UP-	
	57280112009										X						50/48UC-/UP-	
	57280112010											X	X	X			50/48UC-/UP-	
	57280112011							X									50/48UCV/UPV	
	57280112012								X	X							50/48UCV/UPV	
	57280112013										X						50/48UCV/UPV	
	57280112014											X					50/48UCV/UPV	
	57280112015												X	X			50/48UCV/UPV	
	57280112016														X		50/48UCV/UP-	
	57280112017															X	50/48UCV/UP-	
57280112018													X		50/48UCV/UPV			
57280112019														X	50/48UCV/UPV			
Airflow and Refrigerant Safeties																		
Leak Detection (R410A)	57050050021	When the refrigerant is detected by a refrigerant leak detector located after the indoor coil, before the indoor fan of the unit, the controller of the unit gives an alarm and unit is shut down	X	X														
	57050050022				X	X												
	57050050023						X	X	X	X								
	57050050024										X	X	X					
	57050050093														X	X		
Dirty Filter Detection	57050050028	A differential pressure switch that controls the level of filter contamination and informs the controller of the unit.	X	X														
	57050050029				X	X												
	57050050030						X	X	X	X								
	57050050031										X	X	X					
	57050050094														X	X		
Indoor Air Quality																		
CO ₂ sensor	55400010079	Used with the economizer option which consists of two fresh air and return dampers and a motor that are compatible with each other to obtain fresh air ratio at the desired operating conditions of the unit. The economizer is controlled by comparing it with the room, ambient temperature and indoor air quality (CO ₂ sensors. Supplied with a hood and wire cage.	X	X	X	X	X	X	X	X	X	X	X	X	X		142, 143, 146, 147, 148, 149	



Physical Data

50/48 UC/UP-(V)		025	035	045	055	065	075	090	105	125	140	160	190	220
Outdoor Fan / Motor														
Type		Direct Driven Axial												
Fan Quantity	pcs	1	1	1	1	2	2	2	2	2	2	4	4	4
Motor Power Input (Each)	kW	0,84	0,84	1,83	1,76	0,84	1,76	1,76	1,76	1,76	1,76	1,76	1,76	1,76
Motor Speed (High / Low)	rpm	720 / 500	720 / 500	970 / 485	970 / 485	720 / 500	970 / 485	970 / 485	970 / 485	970 / 485	970 / 485	970 / 485	970 / 485	970 / 485
Total Air Flow Rate	m ³ /h	11.988	12.168	18.144	17.712	24.768	35.424	35.424	39.960	39.024	39.744	74.160	83.808	80.208
Fan Diameter	mm	775	775	775	775	775	775	775	775	775	775	775	775	775
Sound Levels														
Sound Power Level 10 ⁻¹² W ⁺	dB(A)	80,7	81,7	82,7	83,2	83,8	83,9	84,0	84,5	84,7	84,7	88,6	92,3	93,9
Sound Pressure Level at 10 m ^{**}	dB(A)	45,8	46,8	47,8	48,3	48,7	48,8	48,9	49,4	49,5	49,5	53,4	56,8	58,4
Indoor Fan / Motor														
Standard Static Pressure														
Motor Quantity	pcs	1	1	1	1	1	1	1	2	2	2	2	3	3
Fan Quantity	pcs	1	1	1	1	1	1	1	2	2	2	2	3	3
Type		EC Plug												
Fan Diameter	mm	400	400	450	560	560	560	560	400	560	560	560	560	560
Nominal Air Flow Rate	m ³ /h	4.205	5.886	7.568	9.250	10.463	11.533	12.500	14.500	19.375	20.981	23.274	30.600	32.832
Motor Speed Range (Min / Max)	rpm	1.000 / 2.480	1.300 / 2.480	1.120 / 2.140	830 / 1.540	840 / 1.540	900 / 1.540	970 / 1.540	1.500 / 2.480	970 / 1.540	1000 / 1.540	1.050 / 1.540	1.050 / 1.540	1.050 / 1.540
Motor Power Input	kW	2,5	2,5	2,9	3,5	3,5	3,5	3,5	2,5	3,5	3,5	3,5	3,5	3,5
Static Pressure Available***	Pa	50	50	50	50	50	50	50	50	50	50	50	50	50
Maximum Static Pressure Available***	Pa	1.150	850	850	750	650	550	450	450	550	450	450	550	450
High Static Pressure														
Motor Quantity	pcs	N/A	N/A	N/A	N/A	N/A	2	2	2	2	2	2	3	3
Fan Quantity	pcs	N/A	N/A	N/A	N/A	N/A	2	2	2	2	2	2	3	3
Type		N/A	N/A	N/A	N/A	N/A	EC Plug							
Fan Diameter	mm	N/A	N/A	N/A	N/A	N/A	560	560	400	560	560	560	560	560
Nominal Air Flow Rate	m ³ /h	N/A	N/A	N/A	N/A	N/A	11.533	12.500	14.500	19.375	20.981	23.274	30.600	32.832
Motor Speed Range (Min / Max)	rpm	N/A	N/A	N/A	N/A	N/A	1.300 / 2.470	1.380 / 2.470	1.500 / 2.750	970 / 1.780	1.000 / 1.780	1.050 / 1.780	1.050 / 1.780	1.050 / 1.780
Motor Power Input	kW	N/A	N/A	N/A	N/A	N/A	2,5	2,5	3,4	5,1	5,1	5,1	5,1	5,1
Static Pressure Available***	Pa	N/A	N/A	N/A	N/A	N/A	50	50	50	50	50	50	50	50
Maximum Static Pressure Available***	Pa	N/A	N/A	N/A	N/A	N/A	850	750	850	950	850	750	950	850
Filters														
Quantity	pcs	4	4	6	6	9	9	9	9	9	9	9	12	12
Filter Size	mm	610 x 610 x 50	610 x 610 x 50	610 x 480 x 50	610 x 480 x 50	565 x 565 x 50	565 x 565 x 50	565 x 565 x 50	565 x 565 x 50	600 x 565 x 50	600 x 565 x 50	600 x 565 x 50	750 x 655 x 50	750 x 655 x 50
Operating Weight (Without Options)														
50UPV	kg	760	830	900	960	1.455	1.551	1.551	1.643	2.205	2.278	2.401	3.050	3.140
50UP-	kg	789	815	904	1.019	1.470	1.580	1.580	1.660	2.260	2.275	2.400	3.070	3.220
48UPV	kg	830	900	977	1.037	1.552	1.648	1.648	1.740	2.352	2.426	2.549	3.310	3.400
48UP-	kg	859	885	981	1.096	1.567	1.677	1.677	1.757	2.408	2.423	2.548	3.330	3.480
50UCV	kg	757	827	894	954	1.448	1.531	1.531	1.629	2.189	2.270	2.393	3.030	3.120
50UC-	kg	787	813	898	1.013	1.460	1.570	1.570	1.650	2.245	2.260	2.385	3.045	3.195
48UCV	kg	827	897	971	1.031	1.545	1.628	1.628	1.726	2.337	2.418	2.541	3.290	3.380
48UC-	kg	857	883	975	1.090	1.557	1.667	1.667	1.747	2.393	2.408	2.533	3.305	3.455
General Dimensions (Without Options)														
Length	mm	2.466	2.466	2.466	2.466	3.608	3.608	3.608	3.608	4.450	4.450	5.080	5.830	5.830
Width	mm	2.196	2.196	2.196	2.196	2.196	2.196	2.196	2.196	2.200	2.200	2.200	2.250	2.250
Height	mm	1.716	1.716	1.918	1.918	2.084	2.084	2.084	2.084	2.110	2.110	2.110	2.360	2.360

*The values have been rounded, for information only and calculated according to ISO 9614-1 standard.

**For information, calculated from the sound power level Lw(A)

***For standard unit at nominal air flow without options

Electrical Data

50/48 UCV*	Unit	025	035	045	055	65	75	90	105	125	140	160	190	220
Power Circuit														
Nominal Power Supply	V-Ph-Hz	400-3-50												
Voltage Range	V	360-440												
Control Circuit Supply		24 V, via Internal Transformer												
Maximum Start-up Current**	A	20	24	35	42	120	138	154	195	217	248	270	319	332
Unit Power Factor at Maximum Capacity***		0,99	0,9	0,91	0,91	0,83	0,88	0,85	0,8	0,79	0,8	0,79	0,78	0,78
Maximum Input Power***	kW	12,75	14,54	21,47	25,97	27,9	37,37	38,79	49,09	52,99	69,8	75,96	83,84	89,8
Nominal Input Current****	A	10,08	16,22	22,06	27,37	32,45	36,94	45,00	63,50	68,47	78,24	90,72	109,73	115,84
Maximum Input Current*****	A	18,60	23,20	34,00	41,30	48,3	61,2	66,3	88,9	96,4	125,4	139,5	154,21	167,02
Customer Control Connection	V	24												
50/48 UC-*	Unit	025	035	045	055	065	075	090	105	125	140	160	190	220
Power Circuit														
Nominal Power Supply	V-Ph-Hz	400-3-50												
Voltage Range	V	360-440												
Control Circuit Supply		24 V, via Internal Transformer												
Maximum Start-up Current**	A	148	153	206	151	125	135	156	206	233	250	278	338	364
Unit Power Factor at Maximum Capacity***		0,70	0,70	0,69	0,69	0,77	0,85	0,77	0,68	0,69	0,68	0,68	0,68	0,68
Maximum Input Power***	kW	13,33	16,08	21,11	25,18	28,42	34,30	37,14	47,84	54,04	61,36	70,28	82,74	94,66
Nominal Input Current****	A	16,21	21,86	28,96	36,62	34,80	37,83	48,24	75,70	82,62	94,59	106,80	121,59	139,78
Maximum Input Current*****	A	27,40	33,40	44,30	52,80	53,40	58,50	69,50	101,10	113,60	129,60	150,10	174,70	200,70
Customer Control Connection	V	24												
50/48 UPV*	Unit	025	035	045	055	65	75	90	105	125	140	160	190	220
Power Circuit														
Nominal Power Supply	V-Ph-Hz	400-3-50												
Voltage Range	V	360-440												
Control Circuit Supply		24 V, via Internal Transformer												
Maximum Start-up Current**	A	20	24	35	42	120	138	154	195	217	248	270	319	332
Unit Power Factor at Maximum Capacity***		0,99	0,9	0,91	0,91	0,83	0,88	0,85	0,80	0,79	0,80	0,79	0,78	0,78
Maximum Input Power***	kW	12,75	14,54	21,47	25,97	27,90	37,37	38,79	49,09	52,99	69,80	75,96	83,84	89,80
Nominal Input Current****	A	0,00	0,00	0,00	0,00	0,00	0,00	0,00	0,00	0,00	0,00	0,00	109,73	115,84
Maximum Input Current*****	A	18,60	23,20	34,00	41,30	48,30	61,20	66,30	88,90	96,40	125,40	139,50	154,21	167,02
Customer Control Connection	V	24												
50/48 UP-*	Unit	025	035	045	055	065	075	090	105	125	140	160	190	220
Power Circuit														
Nominal Power Supply	V-Ph-Hz	400-3-50												
Voltage Range	V	360-440												
Control Circuit Supply		24 V, via Internal Transformer												
Maximum Start-up Current**	A	148	153	206	151	125	135	156	206	233	250	278	338	364
Unit Power Factor at Maximum Capacity***		0,70	0,70	0,69	0,69	0,77	0,85	0,77	0,68	0,69	0,68	0,68	0,68	0,68
Maximum Input Power***	kW	13,33	16,08	21,11	25,18	28,42	34,30	37,14	47,84	54,04	61,36	70,28	82,74	94,66
Nominal Input Current****	A	16,21	21,86	28,96	36,62	34,80	37,83	48,60	75,70	82,62	94,59	106,80	121,59	139,78
Maximum Input Current*****	A	27,40	33,40	44,30	52,80	53,40	58,50	69,50	101,10	113,60	129,60	150,10	174,70	200,70
Customer Control Connection	V	24												

*Standard unit (without any options and accessories)

**Maximum instantaneous start-up current at operating limit values (maximum operating current of the smallest compressor(s) + fan current + locked rotor current of the largest compressor).

***Power input, compressors and fans, at the their operating limits and nominal voltage of 400 V (data given on the unit nameplate).

****Standardised Eurovent conditions: indoor air wet bulb 19 °C, outside air temperature 35 °C with standard fan performance

*****Maximum unit operating current at maximum unit power input and 400 V (values given on the unit nameplate).



Min & Max Air Flow Rates

Model	Air Flow Rate (m ³ /h)	
	Min	Max
025	3.364	5.046
035	4.709	7.063
045	6.054	9.082
055	7.400	11.100
065	8.370	12.556
075	9.226	13.840
090	10.000	15.000
105	11.600	17.400
125	15.500	23.250
140	16.783	25.175
160	18.618	27.928
190	24.480	36.720
220	26.266	39.398

Operating Limits

Cooling Operation			Heat Pump Operation		
Zone	Air Temperature		Zone	Air Temperature	
	Dry Bulb	Wet Bulb		Dry Bulb	Wet Bulb
Indoor			Indoor		
Maximum	+35 °C	+24 °C	Maximum	+27 °C	
Minimum	+18 °C	+13 °C	Minimum	+10 °C	
Outdoor			Outdoor		
Maximum	+52 °C*		Maximum	+22 °C	+18 °C
Minimum	+10 °C		Minimum	-10 °C	-11 °C

Operating Mode	Minimum Outdoor Air Temperature
No compressor running & Free cooling mode	-20 °C
No compressor running & Electric heaters only mode	-20 °C
No compressor running & Hot water coil only mode	-20 °C
No compressor running & Gas burner only mode	-20 °C

*+48°C for UCV/UPV 025, 035, 045, 055, 065, 075, 090, 105, 125, 140, 160, 190 and 220 sizes & +50°C for UC-/UP-025, 035, 045, 055, 105, 125 and 140 sizes & +51°C for UC-/UP- 190 and 220



Sound Ratings

Models	A-Weighted dB(A)	Outdoor Sound Power Level, dB					
		125	250	500	1.000	2.000	4.000
025	80,7	83,5	83,7	75,5	76,1	71,2	66,3
035	81,7	84,5	84,7	76,5	77,1	72,2	67,3
045	82,7	85,5	85,7	77,5	78,1	73,2	68,3
055	83,2	85,9	87,7	78,3	76,5	73,5	69,1
065	83,8	85,5	87,7	79,5	78,4	73,2	68,2
075	83,9	85,6	87,8	79,6	78,7	73,4	67,9
090	84,0	85,6	87,8	79,6	78,7	73,8	68,4
105	84,5	85,8	88,0	79,9	79,4	74,6	69,8
125	84,7	85,7	87,9	79,8	79,9	75,2	70,4
140	84,7	85,3	87,5	79,4	80,1	75,5	71,0
160	88,6	89,3	91,4	83,3	84,2	79,3	75,0
190	92,3	92,7	94,8	86,8	88,0	83,2	79,1
220	93,9	94,1	96,2	88,2	89,7	85,0	80,8

Models	A-Weighted dB(A)	Indoor Sound Power Level, Supply Side, dB					
		125	250	500	1.000	2.000	4.000
025	73,5	66,1	63,0	67,9	69,1	67,2	65,0
035	81,1	71,4	68,9	72,7	76,2	72,5	76,1
045	82,4	75,0	72,7	75,6	76,6	74,2	77,5
055	78,8	71,6	73,6	73,1	72,3	71,1	73,5
065	81,4	75,7	75,7	75,7	74,2	72,2	77,0
075	84,4	78,3	76,0	78,0	76,4	73,5	81,2
090	86,2	81,2	79,2	79,3	78,1	75,4	82,9
105	88,4	76,7	78,2	80,2	83,5	80,9	83,0
125	83,1	77,2	75,9	77,9	77,3	75,2	77,4
140	84,8	79,7	77,4	79,1	78,4	76,5	80,0
160	87,3	82,5	79,6	80,8	80,2	77,9	83,4
190	86,8	83,5	79,6	81,2	80,8	78,9	81,3
220	88,1	83,6	80,5	82,0	82,0	79,7	83,2

Models	A-Weighted dB(A)	Indoor Sound Power Level, Return Side, dB					
		125	250	500	1.000	2.000	4.000
025	68,6	64,4	62,7	62,5	61,4	62,4	62,5
035	77,1	69,4	69,6	69,1	67,7	67,3	74,0
045	79,6	73,6	73,8	71,1	70,0	70,2	76,6
055	75,2	67,7	69,0	65,4	67,4	67,3	71,3
065	78,3	70,3	72,8	67,5	68,9	68,6	75,4
075	82,2	73,7	75,3	69,2	70,9	69,9	80,2
090	83,9	76,0	76,9	70,8	72,7	71,5	81,9
105	84,4	75,5	77,6	76,8	76,0	75,6	80,9
125	79,1	73,2	73,7	69,3	72,0	71,2	75,0
140	81,2	76,1	75,2	70,8	73,2	72,5	77,9
160	84,4	78,9	77,6	72,6	75,1	73,9	81,9
190	82,9	79,5	77,4	72,9	75,5	74,7	79,1
220	84,7	80,8	78,4	73,9	77,0	75,5	81,4



Dimensional Drawings

50 UC-(V)/UP-(V) 025, 035

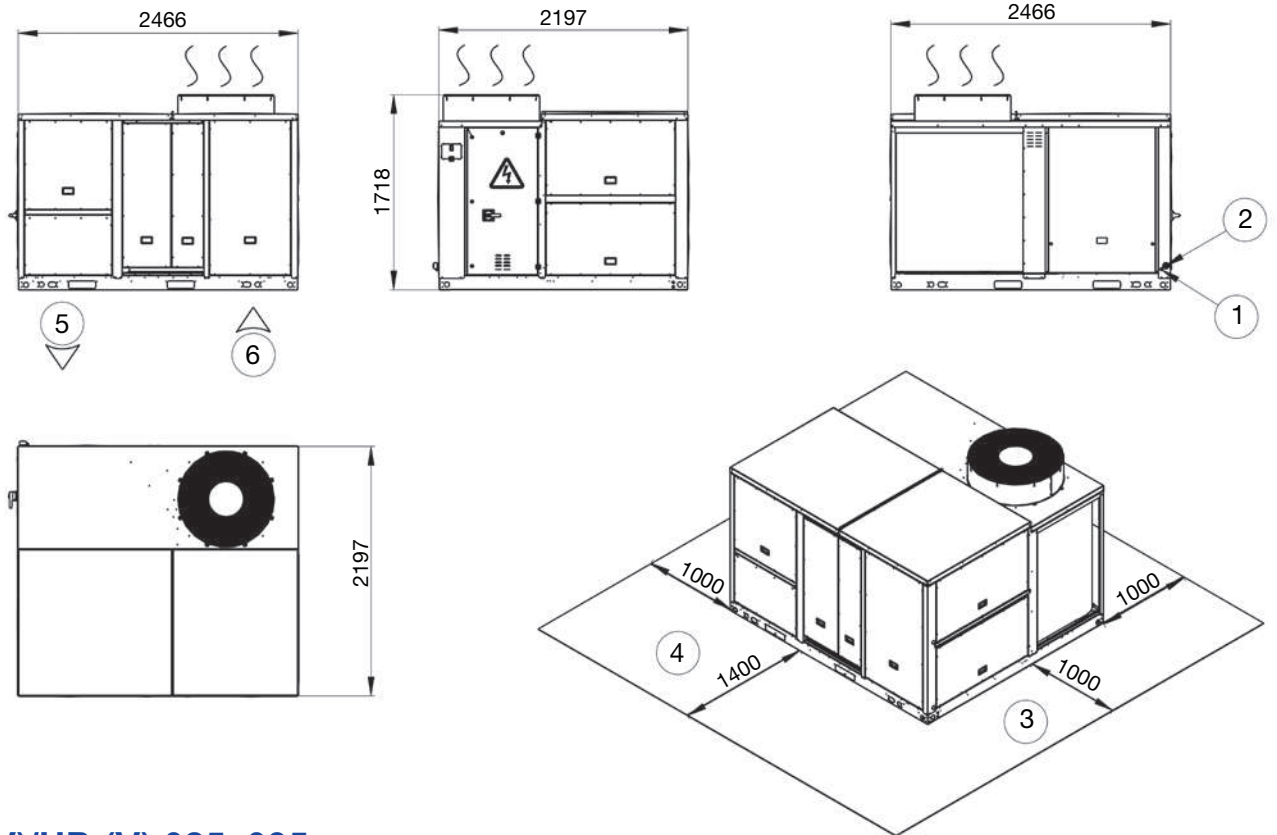

48 UC-(V)/UP-(V) 025, 035

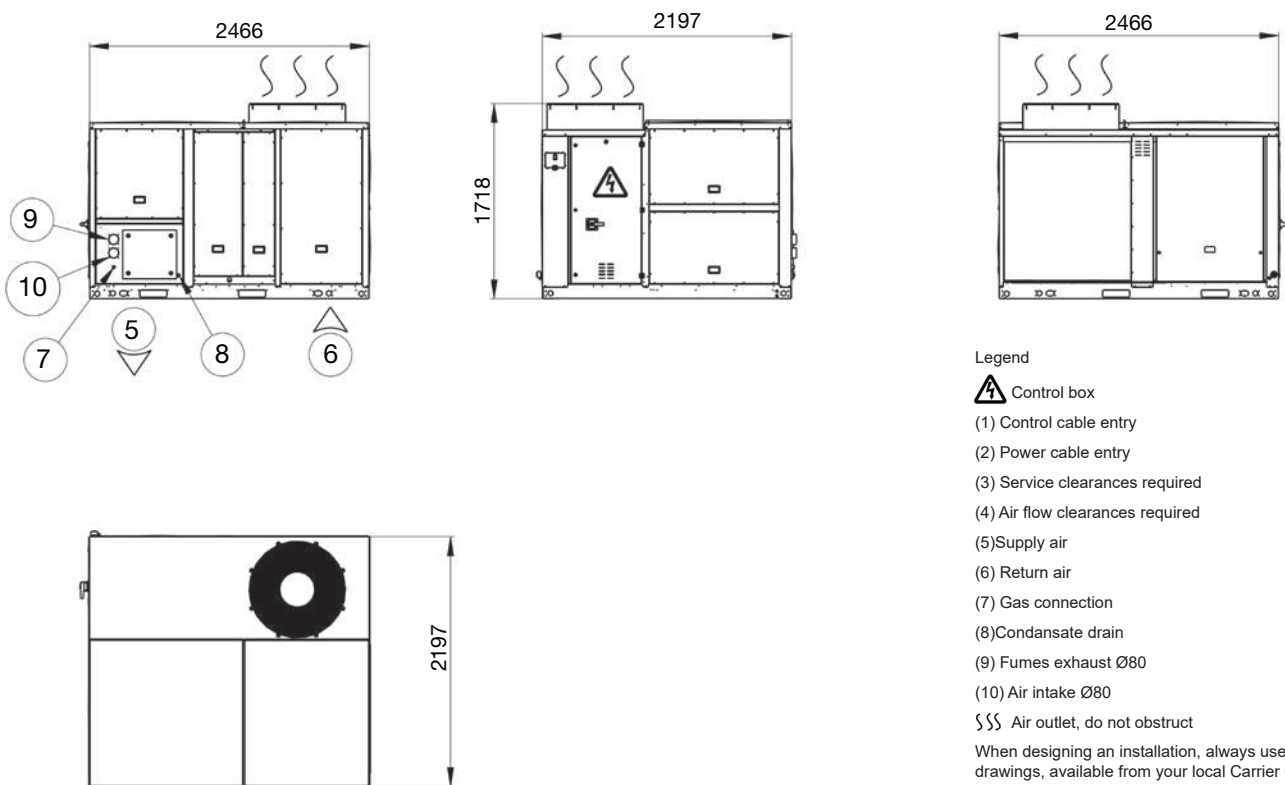

Legend

- Control box
- (1) Control cable entry
- (2) Power cable entry
- (3) Service clearances required
- (4) Air flow clearances required
- (5) Supply air
- (6) Return air
- (7) Gas connection
- (8) Condensate drain
- (9) Fumes exhaust Ø80
- (10) Air intake Ø80
- SSS Air outlet, do not obstruct

When designing an installation, always use up-to-date drawings, available from your local Carrier Office.

Please refer to the certified dimensional drawings for the units with options such as economizer, power exhaust, air return fan, etc.

ttuct

Dimensional Drawings

50 UC-(V)/UP-(V) 045, 055

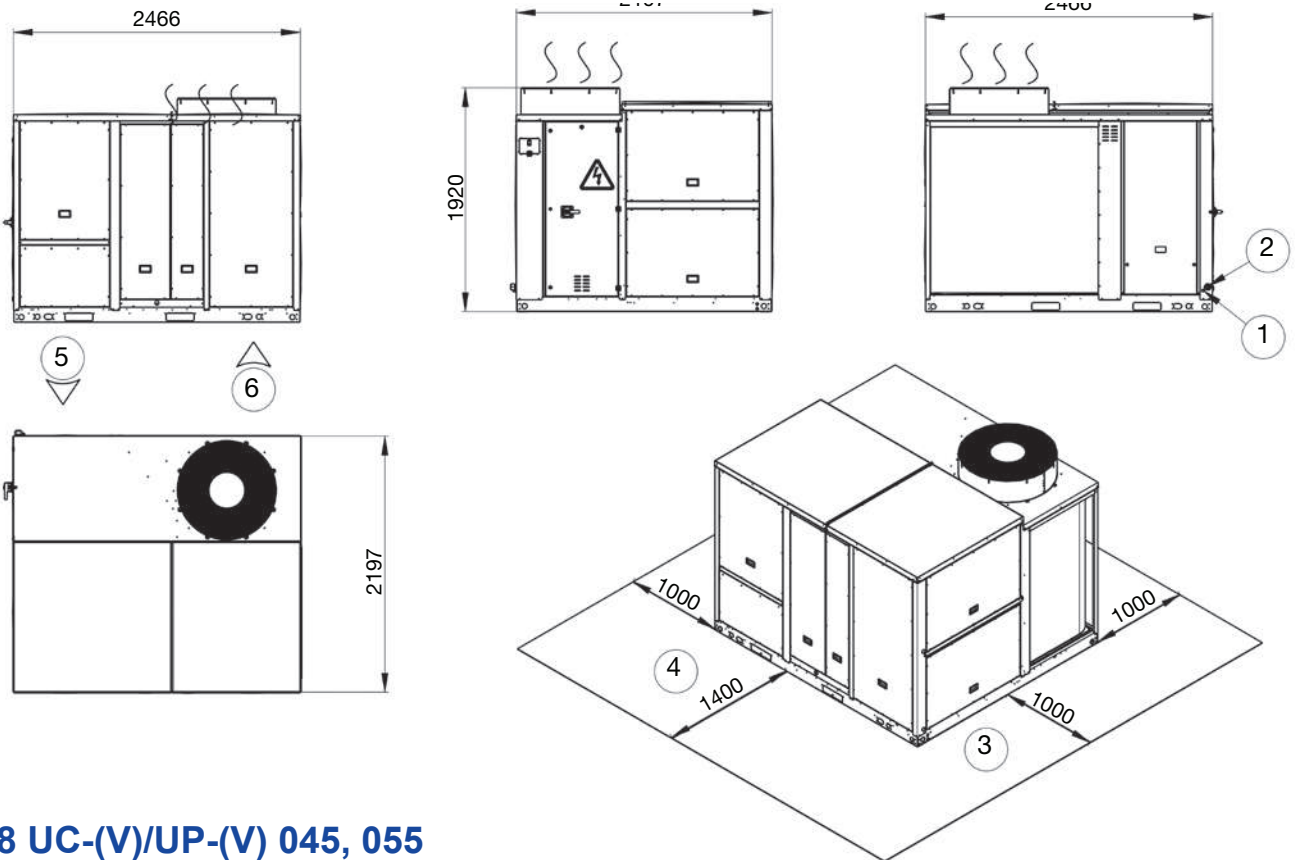

48 UC-(V)/UP-(V) 045, 055

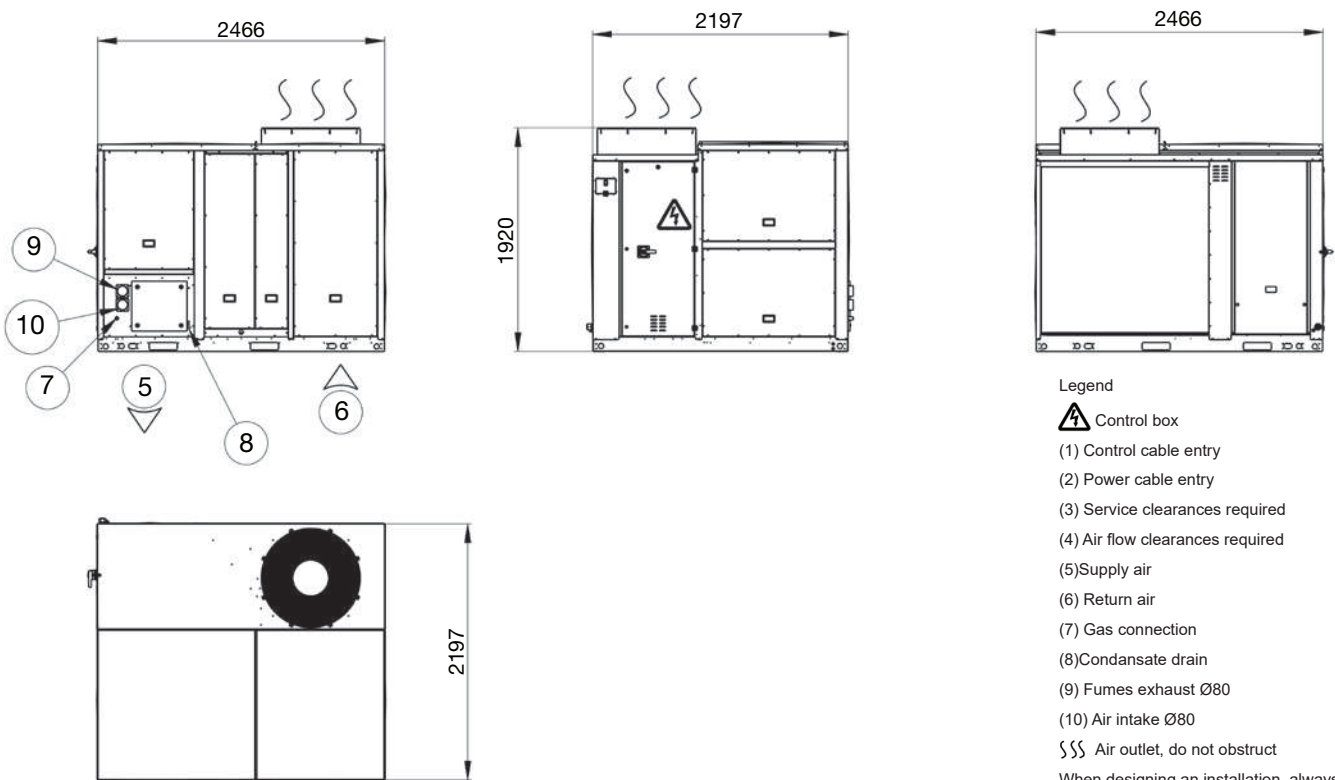

Legend

- Control box
- (1) Control cable entry
- (2) Power cable entry
- (3) Service clearances required
- (4) Air flow clearances required
- (5) Supply air
- (6) Return air
- (7) Gas connection
- (8) Condensate drain
- (9) Fumes exhaust Ø80
- (10) Air intake Ø80
- §§§ Air outlet, do not obstruct

When designing an installation, always use up-to-date drawings, available from your local Carrier Office.

Please refer to the certified dimensional drawings for the units with options such as economizer, power exhaust, air return fan, etc.



Dimensional Drawings

50 UC-(V)/UP-(V) 065, 075, 090, 105

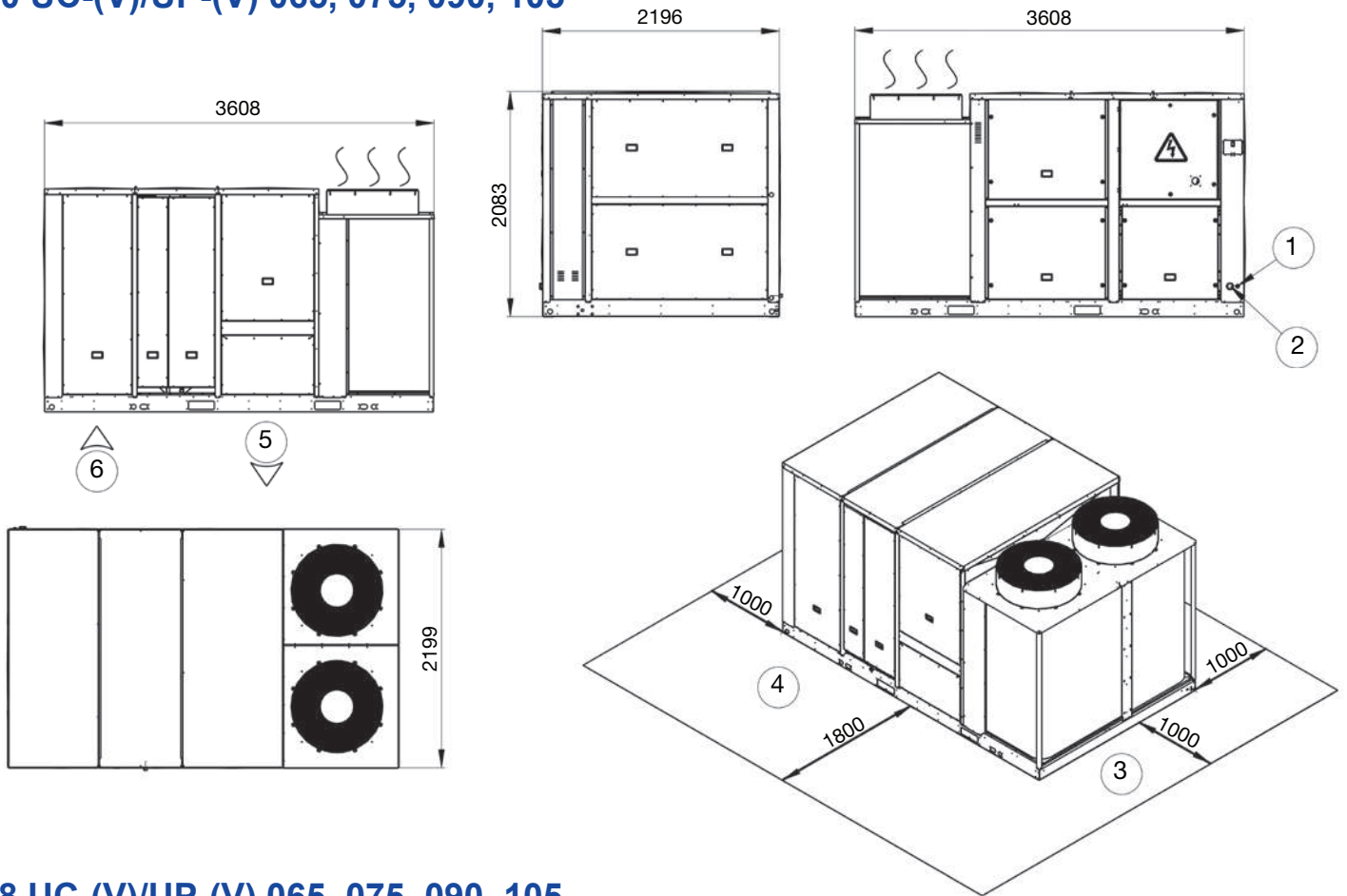

48 UC-(V)/UP-(V) 065, 075, 090, 105

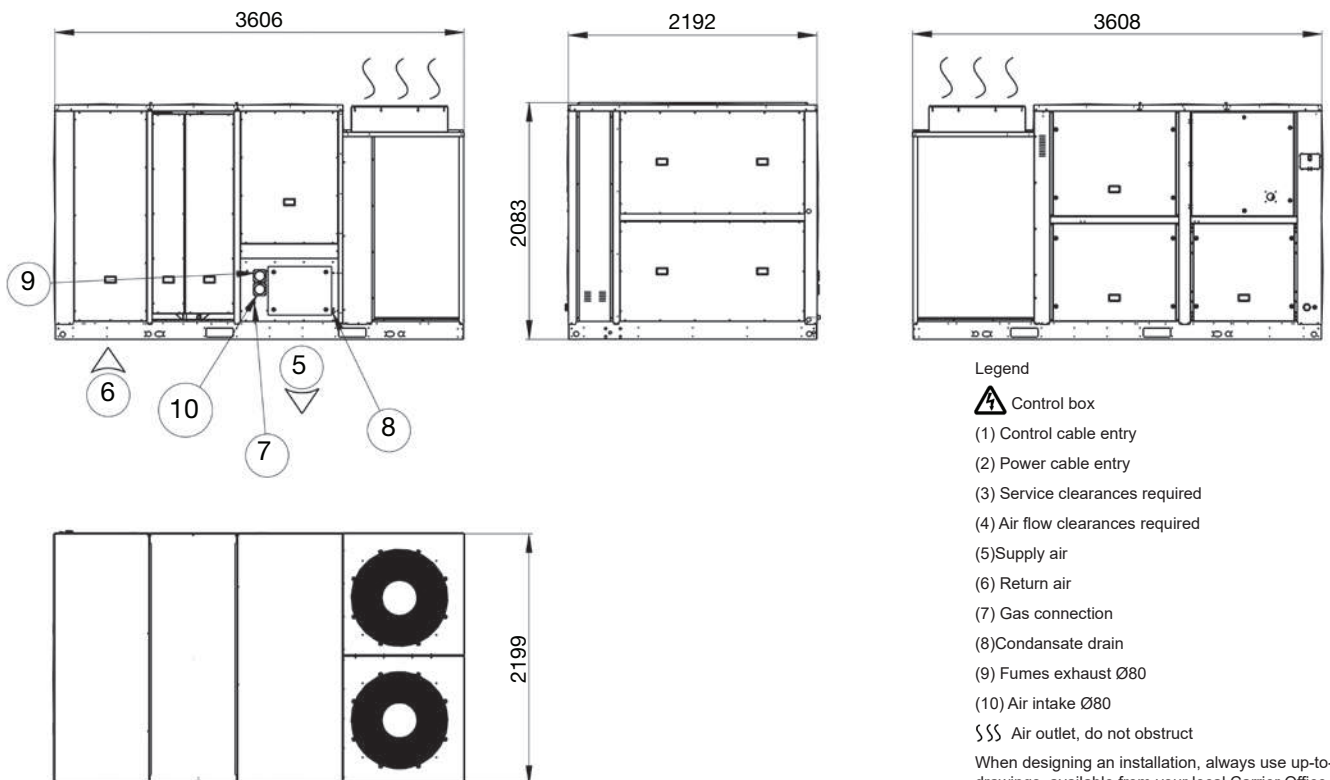

Legend

- Control box
- (1) Control cable entry
- (2) Power cable entry
- (3) Service clearances required
- (4) Air flow clearances required
- (5) Supply air
- (6) Return air
- (7) Gas connection
- (8) Condensate drain
- (9) Fumes exhaust Ø80
- (10) Air intake Ø80
- \$\$\$ Air outlet, do not obstruct

When designing an installation, always use up-to-date drawings, available from your local Carrier Office.

Please refer to the certified dimensional drawings for the units with options such as economizer, power exhaust, air return fan, etc.

Dimensional Drawings

50 UC-(V)/UP-(V) 125, 140

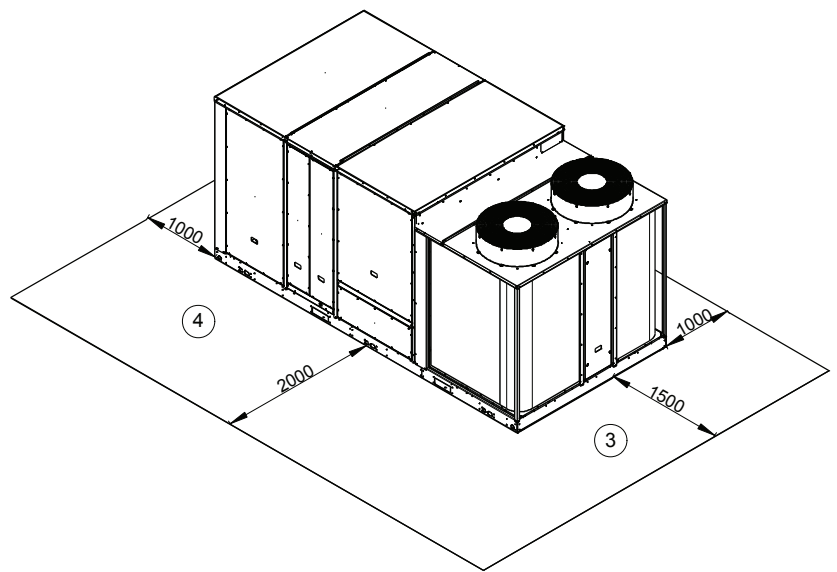
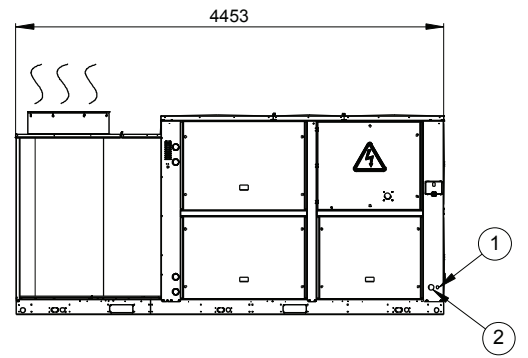
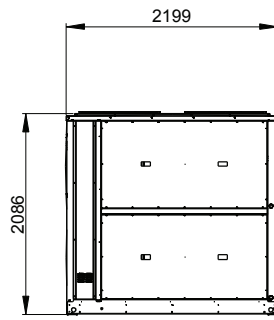
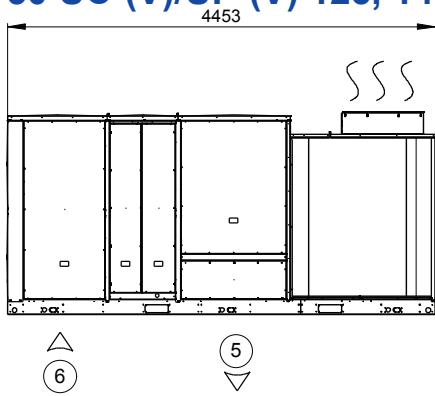



48 UC-(V)/UP-(V) 125, 140

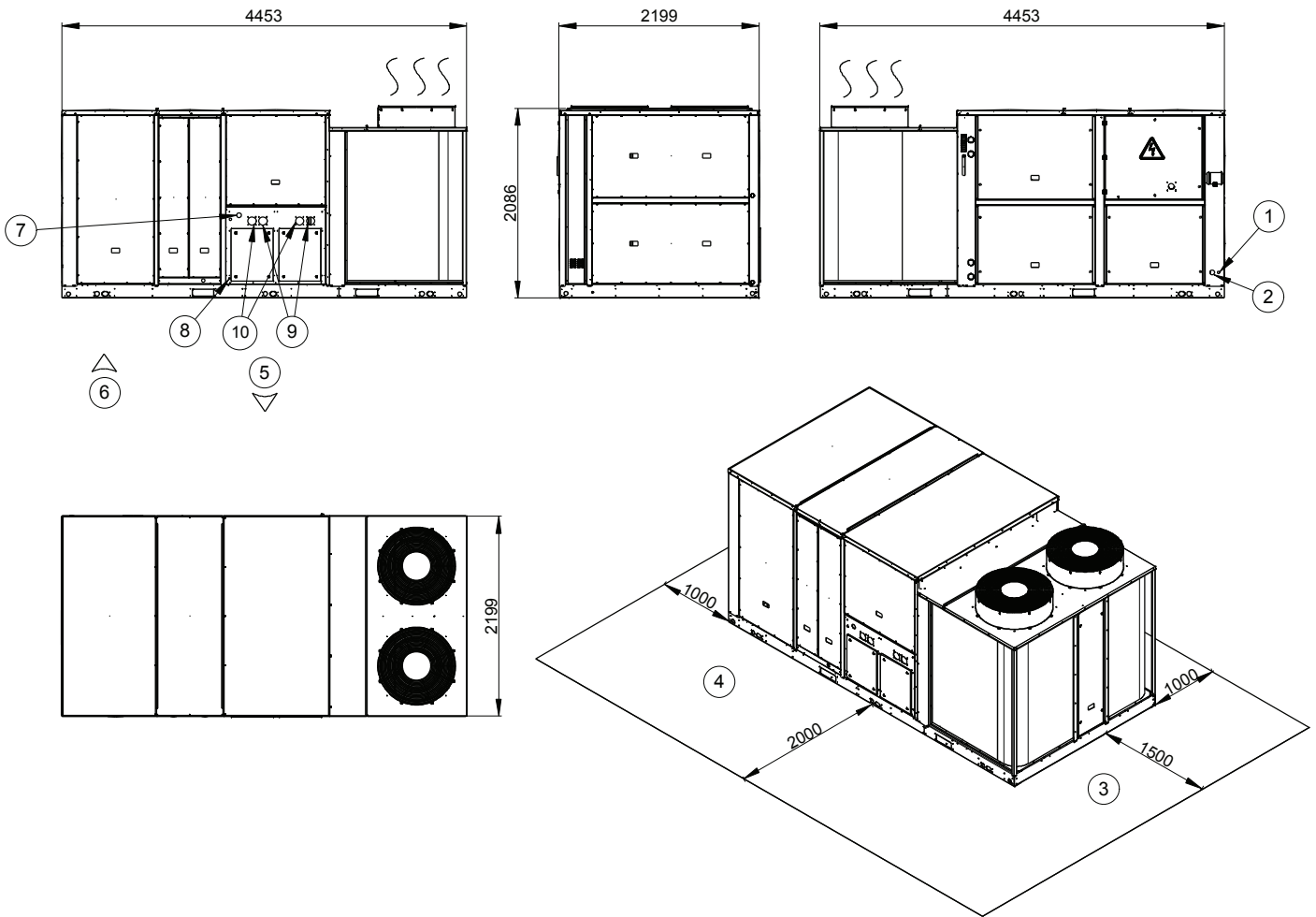

Legend

- Control box
- (1) Control cable entry
- (2) Power cable entry
- (3) Service clearances required
- (4) Air flow clearances required
- (5) Supply air
- (6) Return air
- (7) Gas connection
- (8) Condensate drain
- (9) Fumes exhaust Ø80
- (10) Air intake Ø80
- SSS Air outlet, do not obstruct

When designing an installation, always use up-to-date drawings, available from your local Carrier Office.

Please refer to the certified dimensional drawings for the units with options such as economizer, power exhaust, air return fan, etc.

Dimensional Drawings

50 UC-(V)/UP-(V) 160

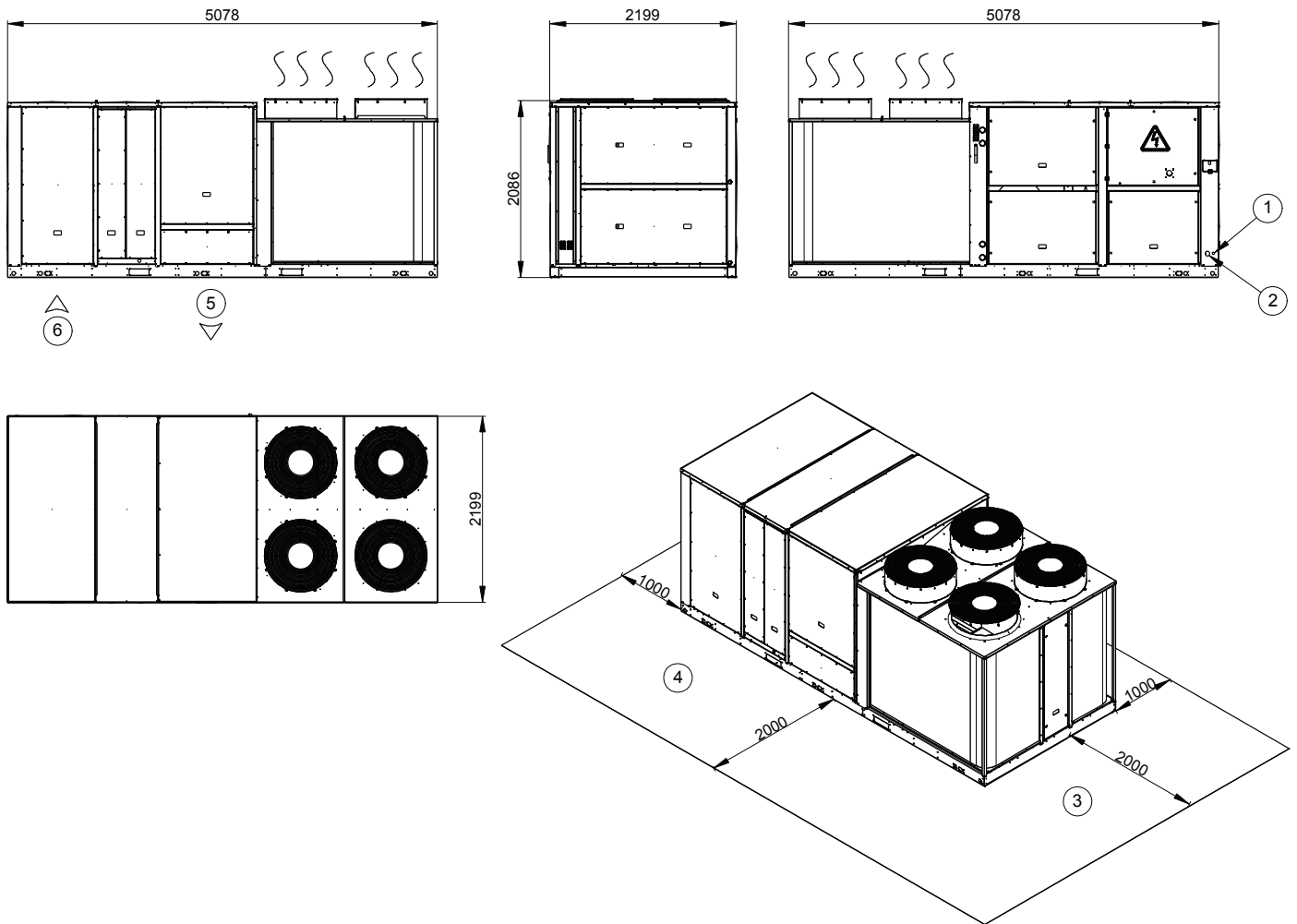

Legend

- Control box
- (1) Control cable entry
- (2) Power cable entry
- (3) Service clearances required
- (4) Air flow clearances required
- (5) Supply air
- (6) Return air
- (7) Gas connection
- (8) Condensate drain
- (9) Fumes exhaust Ø80
- (10) Air intake Ø80
- SSS Air outlet, do not obstruct

When designing an installation, always use up-to-date drawings, available from your local Carrier Office.

Please refer to the certified dimensional drawings for the units with options such as economizer, power exhaust, air return fan, etc.



48 UC-(V)/UP-(V) 160

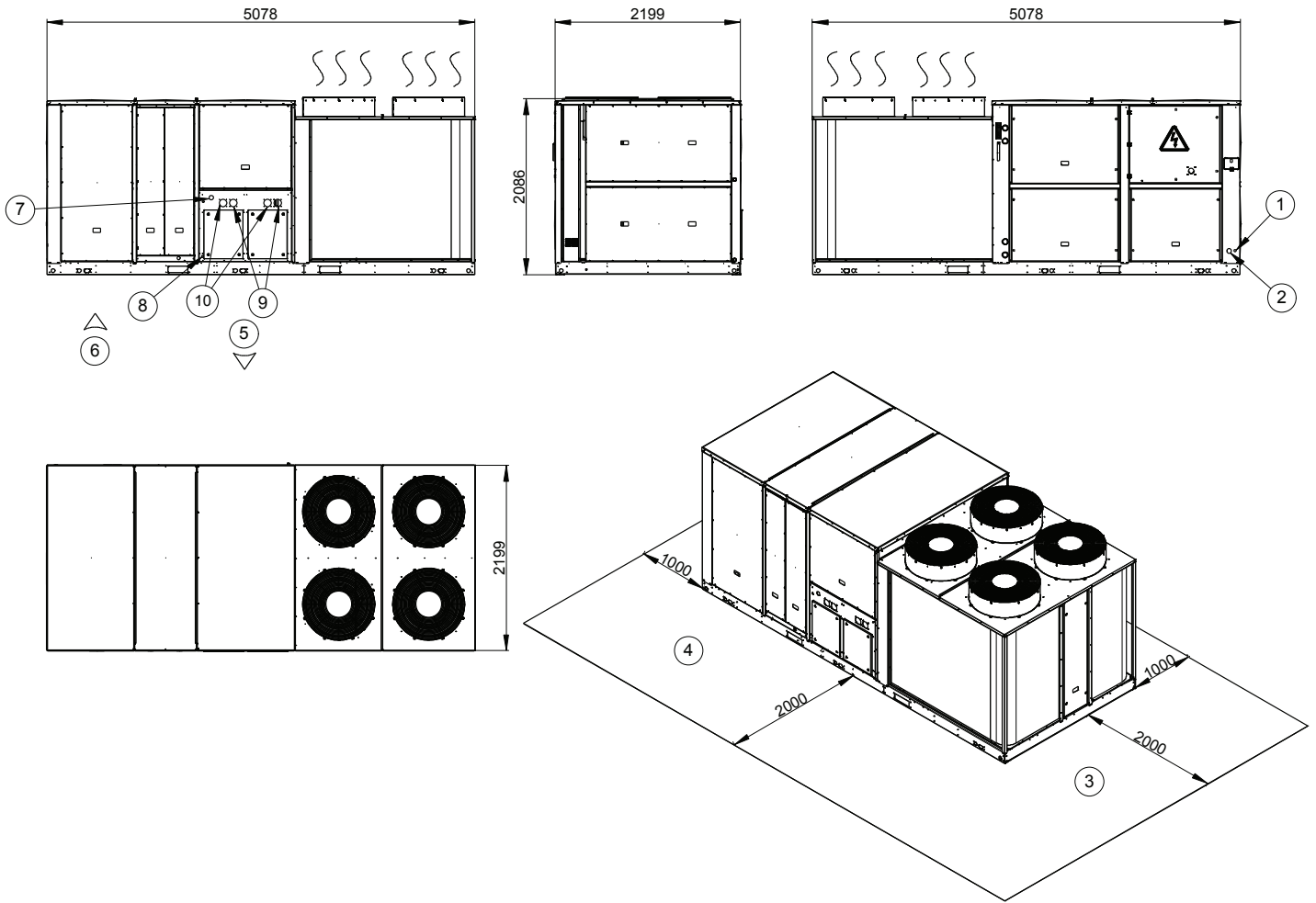

Legend



Control box

(1) Control cable entry

(2) Power cable entry

(3) Service clearances required

(4) Air flow clearances required

(5) Supply air

(6) Return air

(7) Gas connection

(8) Condensate drain

(9) Fumes exhaust Ø80

(10) Air intake Ø80

§§§ Air outlet, do not obstruct

When designing an installation, always use up-to-date drawings, available from your local Carrier Office.

Please refer to the certified dimensional drawings for the units with options such as economizer, power exhaust, air return fan, etc.

50 UC-(V)/UP-(V) 190, 220

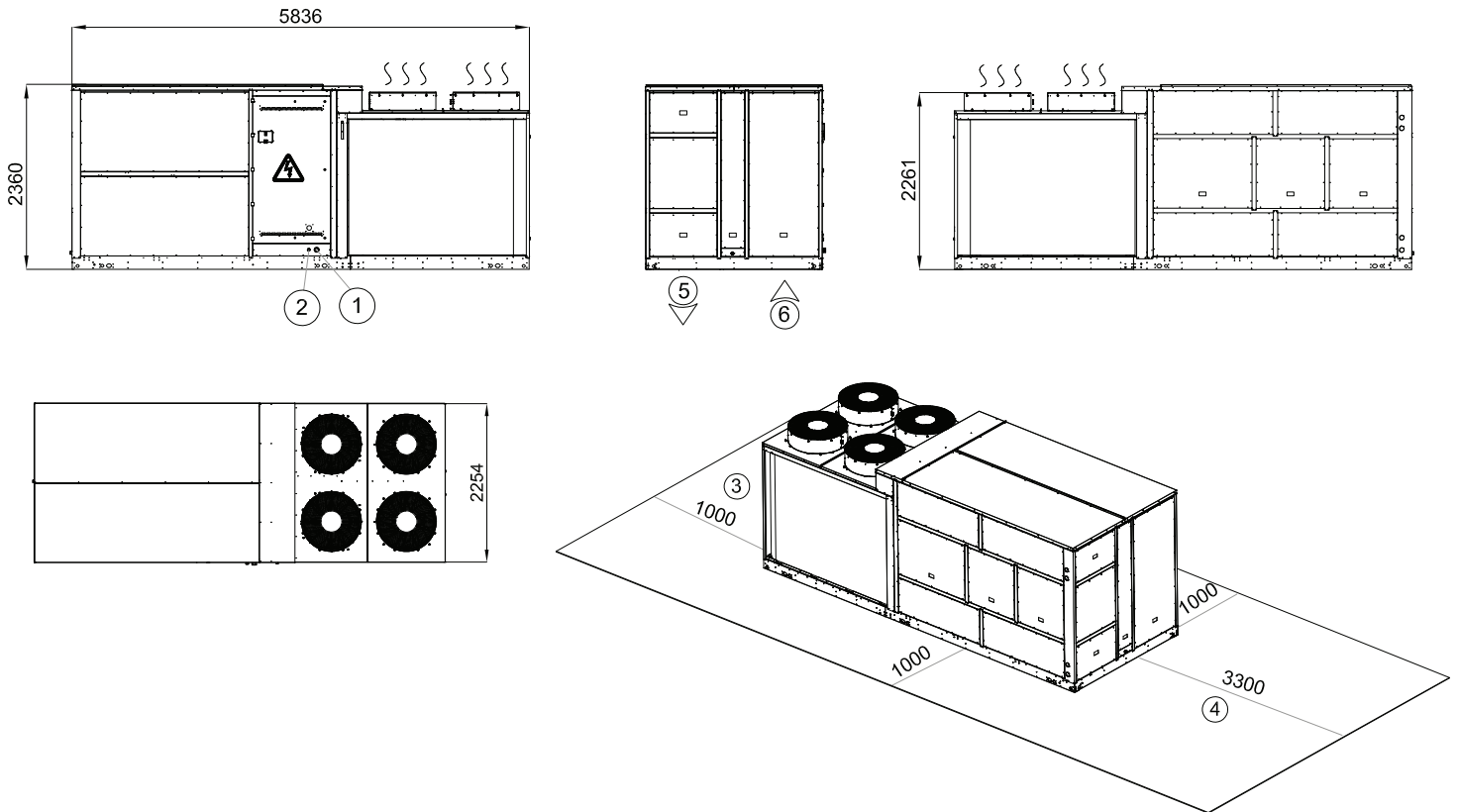

Legend

- Control box
- (1) Control cable entry
- (2) Power cable entry
- (3) Service clearances required
- (4) Air flow clearances required
- (5) Supply air
- (6) Return air
- (7) Gas connection
- (8) Condensate drain
- (9) Fumes exhaust Ø80
- (10) Air intake Ø80
- }}}} Air outlet, do not obstruct

When designing an installation, always use up-to-date drawings, available from your local Carrier Office.

Please refer to the certified dimensional drawings for the units with options such as economizer, power exhaust, air return fan, etc.



50/48 UC-(V)/UP-(V)
Packaged Rooftop Unit

48 UC-(V)/UP-(V) 190, 220

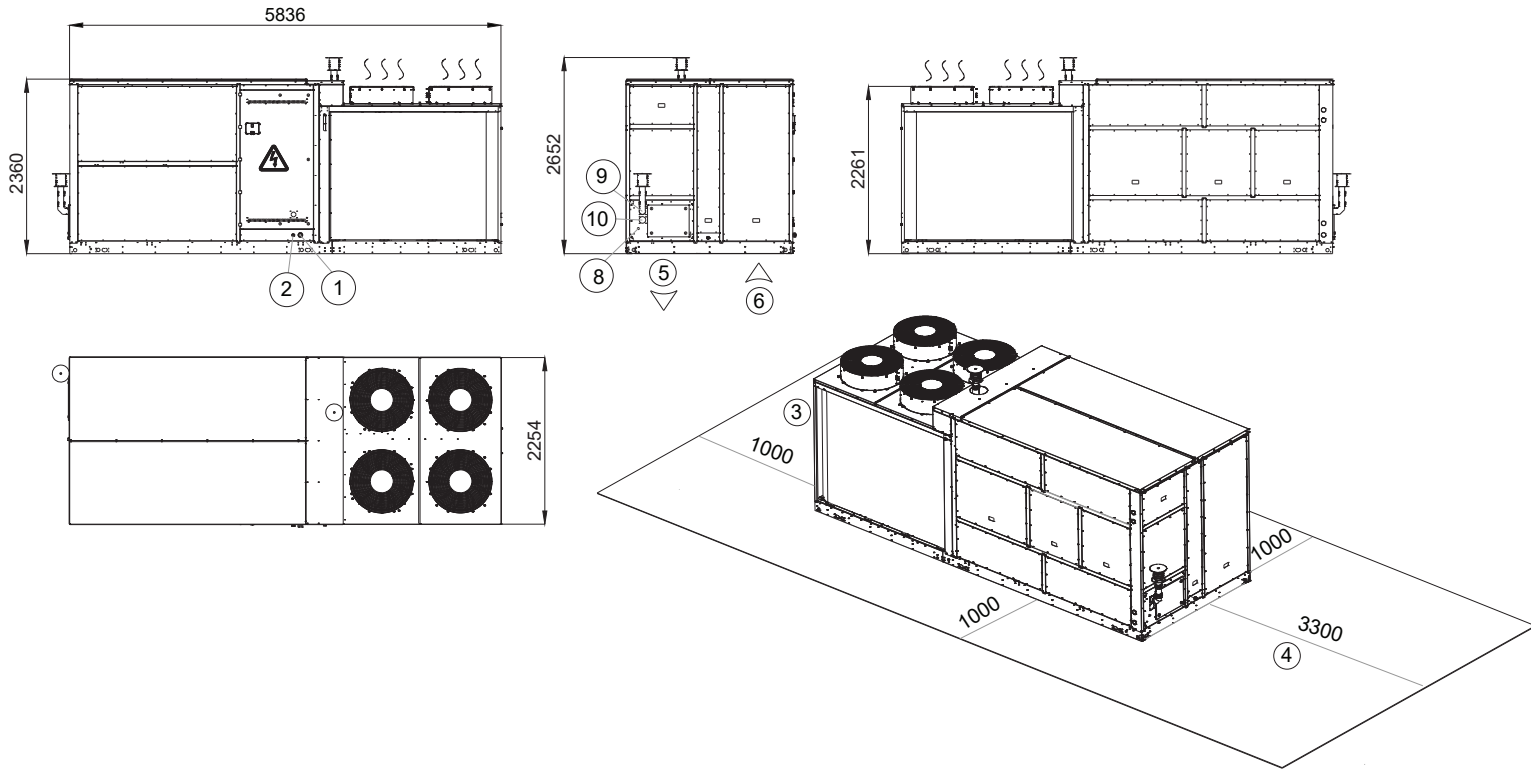

Legend



- (1) Control cable entry
- (2) Power cable entry
- (3) Service clearances required
- (4) Air flow clearances required
- (5) Supply air
- (6) Return air
- (7) Gas connection
- (8) Condensate drain
- (9) Fumes exhaust Ø80
- (10) Air intake Ø80
- SSS Air outlet, do not obstruct

When designing an installation, always use up-to-date drawings, available from your local Carrier Office.

Please refer to the certified dimensional drawings for the units with options such as economizer, power exhaust, air return fan, etc.

Supply Fan

EC Plug		Unit	025			035			045			055			065			075			090					
Air Flow Rate		m ³ /h	Min	Nom	Max	Min	Nom	Max	Min	Nom	Max	Min	Nom	Max	Min	Nom	Max	Min	Nom	Max	Min	Nom	Max			
			3.364	4.205	5.046	4.709	5.886	7.063	6.054	7.568	9.082	7.400	9.250	11.100	8.370	10.463	12.555	9.226	11.533	13.840	10.000	12.500	15.000			
Standard Static Pressure	Static Pressure	Pa	1.250	1.150	1.050	1.050	850	650	950	750	550	850	700	550	850	650	450	750	550	300	650	450	150			
	Fan No		1																							
	Fan Diameter	mm	400						450						560											
	Motor Input Power	kW	2,5						2,9						3,5											
	Motor Speed	rpm	2.480						2.140						1.540											
Maximum Input Current	A	3,8						4,5						5,1												
High Static Pressure	Static Pressure	Pa	N/A	N/A	N/A	N/A	N/A	N/A	N/A	N/A	N/A	N/A	N/A	N/A	N/A	N/A	N/A	1.050	850	600	950	750	450			
	Fan No		2																							
	Fan Diameter	mm	N/A						N/A						N/A						400					
	Motor Input Power	kW	N/A						N/A						N/A						2 x 2,5					
	Motor Speed	rpm	N/A						N/A						N/A						2.480					
Maximum Input Current	A	N/A						N/A						N/A						7,6						

EC Plug		Unit	105			125			140			160			190			220			
Air Flow Rate		m ³ /h	Min	Nom	Max	Min	Nom	Max	Min	Nom	Max	Min	Nom	Max	Min	Nom	Max	Min	Nom	Max	
			11.600	14.500	17.400	15.500	19.375	23.250	16.783	20.981	25.175	18.618	23.274	27.928	24.480	30.600	36.720	26.267	32.832	39.398	
Standard Static Pressure	Static Pressure	Pa	750	450	150	650	550	350	650	450	250	550	450	150	550	550	350	550	450	250	
	Fan No		2																		
	Fan Diameter	mm	400						560						3						
	Motor Input Power	kW	2 x 2,5						2 x 3,5						3 x 3,5						
	Motor Speed	rpm	2.480						1.540						15,3						
Maximum Input Current	A	7,6						10,2						22,8							
High Static Pressure	Static Pressure	Pa	1150	850	450	1050	950	750	1050	850	650	950	750	550	950	950	750	950	850	650	
	Fan No		2																		
	Fan Diameter	mm	400						560						3						
	Motor Input Power	kW	2 x 3,4						2 x 5,1						3 x 5,1						
	Motor Speed	rpm	2.750						1.780						22,8						
Maximum Input Current	A	10,1						15,2						22,8							

Return Fan

EC Plug		Unit	025			035			045			055			065			075			090		
Air Flow Rate		m ³ /h	Min	Nom	Max	Min	Nom	Max	Min	Nom	Max	Min	Nom	Max	Min	Nom	Max	Min	Nom	Max	Min	Nom	Max
			3.364	4.205	5.046	4.709	5.886	7.063	6.054	7.568	9.082	7.400	9.250	11.100	8.370	10.463	12.555	9.226	11.533	13.840	10.000	12.500	15.000
Static Pressure		Pa	950	900	450	850	750	250	750	650	350	750	700	200	850	750	450	1.050	1.000	500	950	800	250
Fan No			1						2						3								
Fan Diameter		mm	310			250			310			355											
Motor Input Power		kW	1,80			2 x 1,18			2 x 1,23			2, x 1,80			2 x 1,90			2 x 2,68					
Motor Speed		rpm	3.410			4.000			3.010			3.410			2.870			3230					
Maximum Input Current		A	2,8			3,6			3,8			5,6			6,0			8,2					

EC Plug		Unit	105			125			140			160			190			220			
Air Flow Rate		m ³ /h	Min	Nom	Max	Min	Nom	Max	Min	Nom	Max	Min	Nom	Max	Min	Nom	Max	Min	Nom	Max	
			11.600	14.500	17.400	15.500	19.375	23.250	16.783	20.981	25.175	18.618	23.274	27.928	24.480	30.600	36.720	26.267	32.832	39.398	
Static Pressure		Pa	950	650	350	850	450	50	950	650	350	850	550	150	950	750	450	950	650	250	
Fan No			2																		
Fan Diameter		mm	400			450			500												
Motor Input Power		kW	2 x 2,5			2 x 2,95			2 x 3,55			3 x 3,55									
Motor Speed		rpm	2480			2150			1920												
Maximum Input Current		A	7,6			9,4			10,6			15,9									

Power Exhaust Fan

Axial / AC	Unit	025	035	045	055	065	075	090	105	125	140	160	190	220
Nominal Air Flow Rate	m ³ /h	4.205	5.886	7.568	9.250	10.463	11.533	12.500	14.500	19.375	20.981	23.274	30.600	32.832
Fan No		1						2			3			
Fan Diameter	mm	460			570									
Motor Input Power	kW	0,65			1,30			2 x 1,30			3 x 1,30			
Motor Speed	rpm	1.400												
Maximum Input Current	A	1,4			2,8			5,6			8,4			



Pressure Drops

50/48 UC-(V)/UP-(V) 025 & 035

Option No	Option Name	Unit Air Flow Rate (m ³ /h)									
		2.880	3.420	3.960	4.500	5.040	5.580	6.120	6.660	7.200	7.740
122	Electric Heater	19	23	26	30	33	37	40	44	48	51
123	Electric Heater	19	23	26	30	33	37	40	44	48	51
125	Hot Water Coil	4	5	6	7	8	9	10	12	13	14
126	Natural Gas Heater	37	49	62	76	92	108	127	146	167	189
127	Natural Gas Heater	23	35	48	61	74	88	102	117	133	149
141	Manual Outdoor Air Damper	3	3	4	5	6	7	8	9	10	12
142, 143, 144, 145	Economizer	3	3	4	5	6	7	8	9	10	12
146, 148	Economizer + Pre-Heater_Low	44	52	60	69	78	87	96	105	114	125
147, 149	Economizer + Pre-Heater_High	44	52	60	69	78	87	96	105	114	125
161	ISO Coarse 65% Filter (G4 Filter)	2	2	3	3	4	4	4	5	5	5
162	ISO ePM1 55% Filter (F7 Filter)	13	16	19	22	25	28	31	34	38	41
163	ISO Coarse 65% + ISO ePM1 55% Filter (G4 + F7 Filter)	30	36	42	49	56	63	70	77	85	92
164	ISO ePM10 75% + ISO ePM1 55% Filter (M6 + F7 Filter)	38	47	56	65	74	84	94	104	114	125
165	ISO ePM1 55% + ISO ePM1 80% Filter (F7 + F9 Filter)	66	80	95	111	127	143	160	177	195	213
175	Thermodynamic HR	4	6	7	8	9	11	12	14	15	16
Option No	Option Name	Fresh Air Flow Rate (m ³ /h)									
		1.080	1.800	2.520	3.240	3.960	4.680	5.400	6.120	6.840	7.740
172, 174, 176, 177	ERM 3.0-5.0-7.0 E/S Fresh Air Filter	12	20	30	40	51	62	75	88	102	117
172	Rotary HR ERM 3.0 E	59	102	146	192	240	291	343	N/A	N/A	N/A
172, 176	Rotary HR ERM 5.0 E	36	61	86	112	139	167	196	225	255	294
176	Rotary HR ERM 7.0 E	28	46	66	86	106	127	148	170	192	220
174	Rotary HR ERM 3.0 S	62	106	153	201	252	304	359	N/A	N/A	N/A
174, 177	Rotary HR ERM 5.0 S	37	63	90	118	146	175	205	236	267	308
177	Rotary HR ERM 7.0 S	29	49	69	90	111	133	155	178	201	230
Option No	Option Name	Exhaust Air Flow Rate (m ³ /h)									
		1.080	1.800	2.520	3.240	3.960	4.680	5.400	6.120	6.840	7.740
172	Rotary HR ERM 3.0 E	59	102	146	192	240	291	343	N/A	N/A	N/A
172, 176	Rotary HR ERM 5.0 E	36	61	86	112	139	167	196	225	255	294
176	Rotary HR ERM 7.0 E	28	46	66	86	106	127	148	170	192	220
174	Rotary HR ERM 3.0 S	62	106	153	201	252	304	359	N/A	N/A	N/A
174, 177	Rotary HR ERM 5.0 S	37	63	90	118	146	175	205	236	267	308
177	Rotary HR ERM 7.0 S	29	49	69	90	111	133	155	178	201	230
175	Thermodynamic HR	5	10	15	21	29	39	50	62	76	90

50/48 UC-(V)/UP-(V) 045 & 055

Option No	Option Name	Unit Air Flow Rate (m ³ /h)									
		5.400	6.120	6.840	7.560	8.280	9.000	9.720	10.440	11.160	11.880
121	Electric Heater	28	32	35	39	43	47	50	54	58	62
122	Electric Heater	28	32	35	39	43	47	50	54	58	62
123	Electric Heater	28	32	35	39	43	47	50	54	58	62
125	Hot Water Coil	7	8	9	10	11	13	14	16	17	19
126	Natural Gas Heater	50	63	77	92	108	124	142	161	181	202
127	Natural Gas Heater	41	50	61	72	84	98	111	126	142	158
141	Manual Outdoor Air Damper	5	6	7	8	10	12	13	15	18	20
142, 143, 144, 145	Economizer	5	6	7	8	10	12	13	15	18	20
146, 148	Economizer + Pre-Heater_Low	68	78	87	97	108	119	129	140	152	163
147, 149	Economizer + Pre-Heater_High	68	78	87	97	108	119	129	140	152	163
161	ISO Coarse 65% Filter (G4 Filter)	3	4	4	4	5	5	5	5	5	5
162	ISO ePM1 55% Filter (F7 Filter)	22	26	29	33	37	40	44	47	51	55
163	ISO Coarse 65% + ISO ePM1 55% Filter (G4 + F7 Filter)	50	58	66	74	82	91	99	108	117	126
164	ISO ePM10 75% + ISO ePM1 55% Filter (M6 + F7 Filter)	66	77	88	99	111	122	134	147	159	171
165	ISO ePM1 55% + ISO ePM1 80% Filter (F7 + F9 Filter)	113	131	150	169	189	209	229	250	271	292
175	Thermodynamic HR	7	8	9	10	12	13	14	15	16	18
Option No	Option Name	Fresh Air Flow Rate (m ³ /h)									
		2.160	3.240	4.320	5.400	6.480	7.560	8.640	9.720	10.800	11.880
172, 174, 176, 177	ERM 7.1-9.1-11.1 C/S Fresh Air Filter	19	30	42	55	69	84	100	118	137	157
172, 174, 176, 177	ERM 11.2 C/S Fresh Air Filter	17	27	37	48	61	74	88	103	119	136
172	Rotary HR ERM 7.1 E	56	86	116	148	181	214	249	285	321	359
172, 176	Rotary HR ERM 9.1 E	44	68	91	116	141	167	193	220	248	276
176	Rotary HR ERM 11.1-11.2 E	36	55	74	93	113	134	154	176	197	219
174	Rotary HR ERM 7.1 S	59	90	112	155	189	224	261	298	337	N/A
174, 177	Rotary HR ERM 9.1 S	46	71	96	121	148	175	202	231	260	289
177	Rotary HR ERM 11.1-11.2 S	38	57	77	98	119	146	162	184	207	230
Option No	Option Name	Exhaust Air Flow Rate (m ³ /h)									
		2.160	3.240	4.320	5.400	6.480	7.560	8.640	9.720	10.800	11.880
172	Rotary HR ERM 7.1 E	56	86	116	148	181	214	249	285	321	359
172, 176	Rotary HR ERM 9.1 E	44	68	91	116	141	167	193	220	248	276
176	Rotary HR ERM 11.1-11.2 E	36	55	74	93	113	134	154	176	197	219
174	Rotary HR ERM 7.1 S	59	90	112	155	189	224	261	298	337	N/A
174, 177	Rotary HR ERM 9.1 S	46	71	96	121	148	175	202	231	260	289
177	Rotary HR ERM 11.1-11.2 S	38	57	77	98	119	146	162	184	207	230
175	Thermodynamic HR	11	19	29	43	59	77	97	119	144	170



50/48 UC-(V)/UP-(V) 065 & 075 & 090 & 105

Option No	Option Description	Unit Air Flow Rate (m ³ /h)									
		7.740	8.820	9.900	10.980	12.060	13.140	14.220	15.300	16.380	17.460
121	Electric Heater	23	26	29	32	35	38	41	45	48	51
122	Electric Heater	23	26	29	32	35	38	41	45	48	51
123	Electric Heater	23	26	29	32	35	38	41	45	48	51
125	Hot Water Coil	7	8	9	10	12	13	15	16	18	20
126	Natural Gas Heater	42	53	65	78	92	108	124	142	161	182
127	Natural Gas Heater	38	47	57	68	79	92	105	120	135	151
128	Natural Gas Heater	37	45	54	64	74	85	97	109	122	136
141	Manual Outdoor Air Damper	3	4	4	5	6	6	7	8	9	10
142, 143, 144, 145	Economizer	3	4	4	5	6	6	7	8	9	10
146, 148	Economizer + Pre-Heater_Low	50	57	64	72	80	86	94	102	110	118
147, 149	Economizer + Pre-Heater_High	50	57	64	72	80	86	94	102	110	118
161	ISO Coarse 65% Filter (G4 Filter)	3	3	4	4	4	5	5	5	5	5
162	ISO ePM1 55% Filter (F7 Filter)	19	22	25	29	32	35	39	42	45	49
163	ISO Coarse 65% + ISO ePM1 55% Filter (G4 + F7 Filter)	43	50	57	64	72	79	87	95	103	111
164	ISO ePM10 75% + ISO ePM1 55% Filter (M6 + F7 Filter)	56	66	76	86	96	107	117	128	139	151
165	ISO ePM1 55% + ISO ePM1 80% Filter (F7 + F9 Filter)	97	113	130	147	164	182	200	219	238	257
175	Thermodynamic HR	6	6	7	7	8	9	10	11	11	12
Option No	Option Description	Fresh Air Flow Rate (m ³ /h)									
		2.232	3.924	5.616	7.308	9.000	10.692	12.384	14.076	15.768	17.460
172, 174, 176, 177	ERM 11.3-13.3-14.3 C/S Fresh Air Filter	11	20	31	43	56	72	90	111	135	163
172, 174, 176, 177	ERM 17.4 C/S Fresh Air Filter	10	19	29	40	52	66	83	101	123	147
172	Rotary HR ERM 11.3 E	37	67	97	129	161	195	230	266	302	340
176	Rotary HR ERM 13.3 E	31	55	80	106	132	159	187	216	245	275
172, 176	Rotary HR ERM 14.3 E	29	52	76	100	125	151	177	204	232	260
176	Rotary HR ERM 17.4 E	24	42	61	80	99	120	140	161	182	204
174	Rotary HR ERM 11.3 S	39	70	102	135	169	204	241	278	317	356
177	Rotary HR ERM 13.3 S	32	58	84	111	138	167	196	226	257	288
174, 177	Rotary HR ERM 14.3 S	31	55	80	105	131	158	186	214	243	272
177	Rotary HR ERM 17.4 S	25	44	64	84	104	125	147	169	191	214
175	Thermodynamic HR	6	12	19	25	35	47	61	76	93	111
Option No	Option Description	Exhaust Air Flow Rate (m ³ /h)									
		2.232	3.924	5.616	7.308	9.000	10.692	12.384	14.076	15.768	17.460
172	Rotary HR ERM 11.3 E	37	67	97	129	161	195	230	266	302	340
176	Rotary HR ERM 13.3 E	31	55	80	106	132	159	187	216	245	275
172, 176	Rotary HR ERM 14.3 E	29	52	76	100	125	151	177	204	232	260
176	Rotary HR ERM 17.4 E	24	42	61	80	99	120	140	161	182	204
174	Rotary HR ERM 11.3 S	39	70	102	135	169	204	241	278	317	356
177	Rotary HR ERM 13.3 S	32	58	84	111	138	167	196	226	257	288
174, 177	Rotary HR ERM 14.3 S	31	55	80	105	131	158	186	214	243	272
177	Rotary HR ERM 17.4 S	25	44	64	84	104	125	147	169	191	214
175	Thermodynamic HR	6	12	19	25	35	47	61	76	93	111

50/48 UC-(V)/UP-(V) 125 & 140

Option No	Option Description	Unit Air Flow Rate (m ³ /h)									
		12.240	13.680	15.120	16.560	18.000	19.440	20.880	22.320	23.760	25.200
121	Electric Heater	50	56	62	68	74	80	86	92	98	105
122	Electric Heater	50	56	62	68	74	80	86	92	98	105
123	Electric Heater	50	56	62	68	74	80	86	92	98	105
124	Hot Water Coil	19	23	28	33	38	43	48	54	60	67
125	Hot Water Coil	35	42	50	59	68	77	87	98	109	121
126	Natural Gas Heater	41	49	59	69	80	92	104	118	132	147
127	Natural Gas Heater	41	52	64	77	91	106	123	140	159	180
128	Natural Gas Heater	42	52	63	76	90	105	121	138	157	176
141	Manual Outdoor Air Damper	5	6	7	8	10	11	13	14	16	18
142, 143, 144, 145	Economizer	5	6	7	8	10	11	13	15	17	19
146, 148	Economizer + Pre-Heater_Low	70	79	88	97	107	116	126	136	146	156
147, 149	Economizer + Pre-Heater_High	70	79	88	97	107	116	126	136	146	156
161	ISO Coarse 65% Filter (G4 Filter)	4	22	24	27	29	32	35	38	40	43
162	ISO ePM1 55% Filter (F7 Filter)	30	54	61	68	75	82	90	97	105	113
163	ISO Coarse 65% + ISO ePM1 55% Filter (G4 + F7 Filter)	68	101	113	126	140	154	168	183	198	214
164	ISO ePM10 75% + ISO ePM1 55% Filter (M6 + F7 Filter)	91	129	146	163	181	199	217	236	256	276
165	ISO ePM1 55% + ISO ePM1 80% Filter (F7 + F9 Filter)	100	141	159	178	198	218	239	261	283	306
175	Thermodynamic HR	8	10	11	12	13	15	16	18	20	22
Option No	Option Description	Fresh Air Flow Rate (m ³ /h)									
		2.160	5.040	7.920	10.800	13.680	16.560	19.440	22.320	25.200	
172, 174, 176, 177	ERM 17.4 C/S Fresh Air Filter	10	25	44	67	97	134	181	239	310	
172, 174, 176, 177	ERM 23.5-28.6 C/S Fresh Air Filter	6	15	25	36	49	64	81	102	125	
172	Rotary HR ERM 17.4 E	23	54	87	121	156	192	230	269	N/A	
176	Rotary HR ERM 23.5 E	17	40	64	88	113	139	165	192	220	
176	Rotary HR ERM 28.6 E	14	34	54	74	95	117	139	162	185	
174	Rotary HR ERM 17.4 S	24	57	91	127	163	202	241	282	N/A	
177	Rotary HR ERM 23.5 S	18	42	67	92	118	145	173	202	231	
177	Rotary HR ERM 28.6 S	15	35	56	78	100	123	146	169	193	
Option No	Option Description	Exhaust Air Flow Rate (m ³ /h)									
		2.160	5.040	7.920	10.800	13.680	16.560	19.440	22.320	25.200	
175	Rotary HR ERM 17.4 E	23	54	87	121	156	192	230	269	N/A	
172	Rotary HR ERM 23.5 E	17	40	64	88	113	139	165	192	220	
174	Rotary HR ERM 28.6 E	14	34	54	74	95	117	139	162	185	
175	Rotary HR ERM 17.4 S	24	57	91	127	163	202	241	282	N/A	
172	Rotary HR ERM 23.5 S	18	42	67	92	118	145	173	202	231	
174	Rotary HR ERM 28.6 S	15	35	56	78	100	123	146	169	193	
175	Thermodynamic HR	6	16	29	47	71	99	131	166	205	



50/48 UC-(V)/UP-(V)
Packaged Rooftop Unit

50/48 UC-(V)/UP-(V) 160

Option No	Option Description	Unit Air Flow Rate (m ³ /h)									
		13.680	15.120	16.560	18.000	19.440	20.880	22.320	23.760	25.200	28.080
121	Electric Heater	56	62	68	74	80	86	92	98	105	117
122	Electric Heater	56	62	68	74	80	86	92	98	105	117
123	Electric Heater	56	62	68	74	80	86	92	98	105	117
125	Hot Water Coil	23	28	33	38	43	48	54	60	67	81
125	Hot Water Coil	42	50	59	68	77	87	98	109	121	145
126	Natural Gas Heater	49	59	69	80	92	104	118	132	147	180
127	Natural Gas Heater	42	52	63	75	88	102	117	133	150	187
128	Natural Gas Heater	42	52	62	74	86	99	113	129	145	180
141	Manual Outdoor Air Damper	6	7	8	10	11	13	14	16	18	22
142, 143, 144, 145	Economizer	6	7	8	10	11	13	15	17	19	23
146, 148	Economizer + Pre-Heater_Low	79	88	97	107	116	126	136	146	156	177
147, 149	Economizer + Pre-Heater_High	79	88	97	107	116	126	136	146	156	177
161	ISO Coarse 65% Filter (G4 Filter)	22	24	27	29	32	35	38	40	43	51
162	ISO ePM1 55% Filter (F7 Filter)	54	61	68	75	82	90	97	105	113	125
163	ISO Coarse 65% + ISO ePM1 55% Filter (G4 + F7 Filter)	101	113	126	140	154	168	183	198	214	232
164	ISO ePM10 75% + ISO ePM1 55% Filter (M6 + F7 Filter)	129	146	163	181	199	217	236	256	276	298
165	ISO ePM1 55% + ISO ePM1 80% Filter (F7 + F9 Filter)	141	159	178	198	218	239	261	283	306	331
175	Thermodynamic HR	10	11	12	13	15	16	18	20	22	26
Option No	Option Description	Fresh Air Flow Rate (m ³ /h)									
		2.160	5.040	7.920	10.800	13.680	16.560	19.440	22.320	25.200	28.080
172, 174, 176, 177	ERM 23.5-28.6 C/S Fresh Air Filter	6	15	25	36	49	64	81	102	125	152
172	Rotary HR ERM 23.5 E	17	40	64	88	113	139	165	192	220	249
176	Rotary HR ERM 28.6 E	14	34	54	74	95	117	139	162	185	208
174	Rotary HR ERM 23.5 S	18	42	67	92	118	145	173	202	231	261
177	Rotary HR ERM 28.6 S	15	35	56	78	100	123	146	169	193	218
Option No	Option Description	Exhaust Air Flow Rate (m ³ /h)									
		2.160	5.040	7.920	10.800	13.680	16.560	19.440	22.320	25.200	28.080
172	Rotary HR ERM 23.5 E	17	40	64	88	113	139	165	192	220	249
176	Rotary HR ERM 28.6 E	14	34	54	74	95	117	139	162	185	208
174	Rotary HR ERM 23.5 S	18	42	67	92	118	145	173	202	231	261
177	Rotary HR ERM 28.6 S	15	35	56	78	100	123	146	169	193	218
175	Thermodynamic HR	6	16	29	47	71	99	131	166	205	248

50/48 UC-(V)/UP-(V) 190 & 220

Option No	Option Description	Unit Air Flow Rate (m ³ /h)									
		23.760	25.200	26.640	28.080	29.520	31.176	35.640	37.260	38.880	40.500
121	Electric Heater	65	69	73	77	81	86	99	103	108	112
122	Electric Heater	65	69	73	77	81	86	99	103	108	112
123	Electric Heater	65	69	73	77	81	86	99	103	108	112
125	Hot Water Coil	32	35	39	43	47	51	65	70	75	81
125	Hot Water Coil	60	66	73	80	87	95	118	126	135	143
127	Natural Gas Heater	72	79	88	96	104	114	123	134	145	150
128	Natural Gas Heater	80	90	100	110	117	130	140	150	160	166
141	Manual Outdoor Air Damper	6	7	7	8	9	10	13	14	15	16
142, 143, 144, 145	Economizer	6	7	7	8	9	10	13	14	15	16
146, 148	Economizer + Pre-Heater_Low	146	156	166	176	186	197	228	239	250	261
147, 149	Economizer + Pre-Heater_High	146	156	166	176	186	197	228	239	250	261
161	ISO Coarse 65% Filter (G4 Filter)	4	4	5	5	5	5	5	5	5	5
162	ISO ePM1 55% Filter (F7 Filter)	30	32	34	36	39	41	48	50	52	55
163	ISO Coarse 65% + ISO ePM1 55% Filter (G4 + F7 Filter)	67	72	77	82	87	93	109	114	120	126
164	ISO ePM10 75% + ISO ePM1 55% Filter (M6 + F7 Filter)	90	97	103	110	117	125	147	155	163	171
165	ISO ePM1 55% + ISO ePM1 80% Filter (F7 + F9 Filter)	154	165	176	188	200	213	251	264	278	292
Option No	Option Description	Fresh Air Flow Rate (m ³ /h)									
		6.480	12.240	17.280	20.880	24.480	28.080	31.680	35.280	38.880	40.500
172, 174, 176, 177	ERM 29.6 C/S Fresh Air Filter	18	39	62	82	106	134	167			
172, 174, 176, 177	ERM 40.7 C/S Fresh Air Filter	12	25	38	49	61	74	89	106	125	135
172	Rotary HR ERM 29.6 E	28	54	79	98	117	137	157			
176	Rotary HR ERM 40.7 E	20	38	55	68	81	94	107	121	135	142
174	Rotary HR ERM 29.6 S	29	57	83	102	122	143	165			
177	Rotary HR ERM 40.7 S	21	40	58	71	84	98	112	127	142	149
Option No	Option Description	Exhaust Air Flow Rate (m ³ /h)									
		6.480	12.240	17.280	20.880	24.480	28.080	31.680	35.280	38.880	40.500
172	Rotary HR ERM 29.6 E	28	54	79	98	117	137	157			
176	Rotary HR ERM 40.7 E	20	38	55	68	81	94	107	121	135	142
174	Rotary HR ERM 29.6 S	29	57	83	102	122	143	165			
177	Rotary HR ERM 40.7 S	21	40	58	71	84	98	112	127	142	149

Electrical Heater

50 UC-(V)/UP-(V)	Option No	Min / Max Heat Output kW	Nominal Input Current A	Capacity Steps
025	122	9,0 / 18,0	26	2
	123	6,0 / 18,0 / 30,0	43	3
035	122	9,0 / 18,0	26	2
	123	6,0 / 18,0 / 30,0	43	3
045	121	6,9 / 20,7	30	2
	122	6,9 / 13,8 / 27,6	40	3
	123	13,8 / 27,6 / 41,4	60	3
055	121	6,9 / 20,7	30	2
	122	6,9 / 13,8 / 27,6	40	3
	123	13,8 / 27,6 / 41,4	60	3
065	121	9,0 / 18,0	26	2
	122	9,0 / 18,0 / 36,0	52	3
	123	18,0 / 36,0 / 54,0	78	3
075	121	9,0 / 18,0 / 27,0	39	3
	122	9,0 / 18,0 / 36,0	52	3
	123	18,0 / 36,0 / 54,0	78	3
090	121	9,0 / 18,0 / 27,0	39	3
	122	9,0 / 27,0 / 45,0	65	3
	123	18,0 / 45,0 / 72,0	104	3
105	121	9,0 / 18,0 / 27,0	39	3
	122	9,0 / 27,0 / 45,0	65	3
	123	18,0 / 45,0 / 72,0	104	3
125	121	11,1 / 22,2 / 44,4	64	3
	122	22,2 / 44,4 / 66,6	96	3
	123	22,2 / 55,5 / 99,9	144	3
140	121	11,1 / 33,3 / 55,5	80	3
	122	22,2 / 55,5 / 88,8	128	3
	123	33,3 / 77,7 / 133,2	192	3
160	121	11,1 / 33,3 / 55,5	80	3
	122	22,2 / 55,5 / 88,8	128	3
	123	33,3 / 77,7 / 133,2	192	3
190	121	9,0 / 18,0 / 36,0 / 54,0	78	4
	122	18,0 / 36,0 / 63,0 / 90,0	130	4
	123	36,0 / 72,0 / 108,0 / 144,0	208	4
220	121	9,0 / 18,0 / 36,0 / 54,0	78	4
	122	18,0 / 36,0 / 63,0 / 90,0	130	4
	123	36,0 / 72,0 / 108,0 / 144,0	208	4

Nominal Power Supply: 400V-3Ph-50Hz



Natural Gas Heater

48 UC-(V)/UP-(V)	Option No	Min / Max Net Heat Input	Min / Max Heat Output
		kW	kW
025	126	7,60 / 34,85	8,13 / 33,56
	127	8,50 / 42,00	8,97 / 40,45
035	126	7,60 / 34,85	8,13 / 33,56
	127	8,50 / 42,00	8,97 / 40,45
045	126	8,50 / 42,00	8,97 / 40,45
	127	12,40 / 65,00	13,40 / 62,93
055	126	8,50 / 42,00	8,97 / 40,45
	127	12,40 / 65,00	13,40 / 62,93
065	126	12,40 / 65,00	13,40 / 62,93
	127	16,40 / 82,00	17,77 / 80,03
	128	21,00 / 100,00	22,77 / 97,15
075	126	12,40 / 65,00	13,40 / 62,93
	127	16,40 / 82,00	17,77 / 80,03
	128	21,00 / 100,00	22,77 / 97,15
090	126	12,40 / 65,00	13,40 / 62,93
	127	16,40 / 82,00	17,77 / 80,03
	128	21,00 / 100,00	22,77 / 97,15
105	126	12,40 / 65,00	13,40 / 62,93
	127	16,40 / 82,00	17,77 / 80,03
	128	21,00 / 100,00	22,77 / 97,15
125	126	12,40 / 65,00	22,77 / 97,15
	127	16,40 / 82,00	17,77 / 160,06
	128	21,00 / 100,00	22,77 / 194,30
140	126	21,00 / 100,00	22,77 / 97,15
	127	16,40 / 164,00	17,77 / 160,06
	128	21,00 / 200,00	22,77 / 194,30
160	126	21,00 / 100,00	22,77 / 97,15
	127	16,40 / 164,00	17,77 / 160,06
	128	21,00 / 200,00	22,77 / 194,30
190	127	16,4 / 164,00	17,77 / 160,06
	128	21,0 / 200,00	22,77 / 194,30
220	127	16,4 / 164,00	17,77 / 160,06
	128	21,0 / 200,00	22,77 / 194,30

Heating Modules	Unit	PCH 034	PCH 045	PCH 065	PCH 080	PCH 105	PCH 160	PCH 210
Net Heat Input (Min / Max)	kW	7,60 / 34,85	8,50 / 42,00	12,40 / 65,00	16,40 / 82,00	21,00 / 100,00	16,40 / 164,00	21,00 / 200,00
Heat Output (Min / Max)	kW	8,13 / 33,56	8,97 / 40,45	13,40 / 62,93	17,77 / 80,03	22,77 / 97,15	17,77 / 160,10	22,77 / 194,30
Seasonal Space Heating Energy Efficiency [$\eta_{s,h}$] ^{***}	%	92,1	90,8	93,2	93,2	93,1	94,0	94,0
Emission Efficiency [$\eta_{s,flow}$] ^{***}	%	97,3	97,0	97,4	97,1	97,0	97,9	97,9
Natural Gas Rate (G20)*	m ³ /h	0,80 / 3,69	0,90 / 4,44	1,31 / 6,88	1,74 / 8,68	2,22 / 10,58	3,48 / 17,36	4,44 / 21,16
Pilot Nozzle								
Quantity	psc	1	1	1	1	1	2	2
Size	mm	0,7	0,7	0,7	0,7	0,7	0,7	0,7
Weight**	kg	48	58	72	98	118	206	250
Input Power (230V-1Ph-50Hz)**	W	11 / 74	15 / 65	15 / 97	20 / 123	20 / 130	20 / 246	20 / 260
Gas Connection		UNI/ISO 228/1-G 3/4"						

*Natural gas (G20) net calorific value 34.02 MJ/m³ @ 15°C, 1,013 mbar.

**Weight and power input values are valid for the heating modules.

***EU 2281/2016 Regulation

Hot Water Coil

50 UC-(V)/UP-(V) 025 & 035

Air Flow Rate	Capacity*	Air Outlet Dry Bulb Temperature	Air Pressure Drop	Water Flow Rate	Water Pressure Drop
m ³ /h	kW	°C	Pa	m ³ /h	kPa
2.880	28,3	42,3	4	1,21	13,14
3.168	30,4	41,7	5	1,31	14,90
3.456	32,6	41,2	5	1,40	16,68
3.744	34,6	40,6	6	1,49	18,47
4.032	36,6	40,1	6	1,58	20,28
4.320	38,4	39,5	7	1,65	21,96
4.608	40,1	39,0	7	1,72	23,66
4.896	41,7	38,5	8	1,79	25,37
5.184	43,3	38,0	8	1,86	27,09
5.472	44,9	37,5	9	1,93	28,79
5.760	46,4	37,1	10	2,00	30,51
6.048	47,9	36,7	11	2,06	32,22
6.336	49,3	36,3	11	2,12	33,94
6.624	50,7	35,9	12	2,18	35,65
6.912	52,1	35,5	12	2,24	37,37
7.200	53,5	35,2	13	2,30	39,10
7.488	54,8	34,9	14	2,36	40,84
7.776	56,1	34,6	15	2,41	42,55
8.064	57,4	34,3	15	2,47	44,26

*Based on 90°C entering water temperature, 20°C water temperature drop, 13°C entering air temperature.

50 UC-(V)/UP-(V) 045 & 055

Air Flow Rate	Capacity*	Air Outlet Dry Bulb Temperature	Air Pressure Drop	Water Flow Rate	Water Pressure Drop
m ³ /h	kW	°C	Pa	m ³ /h	kPa
5.400	51,9	41,7	7	2,23	18,79
5.760	54,1	41,1	8	2,33	20,13
6.120	56,4	40,5	8	2,42	21,49
6.480	58,5	40,0	9	2,52	22,83
6.840	60,7	39,5	9	2,61	24,19
7.200	62,7	39,0	10	2,70	25,56
7.560	64,7	38,6	10	2,78	26,94
7.920	66,7	38,2	11	2,87	28,31
8.280	68,6	37,8	11	2,95	29,69
8.640	70,5	37,4	12	3,03	31,07
9.000	72,3	37,0	13	3,11	32,46
9.360	74,1	36,7	14	3,19	33,83
9.720	75,9	36,3	14	3,26	35,22
10.080	77,6	36,0	15	3,33	36,59
10.440	79,3	35,7	15	3,41	37,97
10.800	80,9	35,4	16	3,48	39,34
11.160	82,5	35,1	17	3,55	40,73
11.520	84,1	34,8	18	3,62	42,10
11.880	85,7	34,6	18	3,69	43,49

*Based on 90°C entering water temperature, 20°C water temperature drop, 13°C entering air temperature.



50 UC-(V)/UP-(V) 065 & 075 & 090 & 105

Air Flow Rate	Capacity*	Air Outlet Dry Bulb Temperature	Air Pressure Drop	Water Flow Rate	Water Pressure Drop
m ³ /h	kW	°C	Pa	m ³ /h	kPa
7.920	84,2	44,8	5	3,62	12,35
8.460	88,4	44,2	6	3,80	13,49
9.000	92,6	43,7	6	3,98	14,64
9.540	96,2	43,1	7	4,14	15,71
10.080	99,9	42,6	7	4,30	16,79
10.620	103,4	42,1	8	4,45	17,88
11.160	106,9	41,6	8	4,60	18,97
11.700	110,2	41,1	9	4,74	20,07
12.240	113,5	40,7	9	4,88	21,17
12.780	116,7	40,3	10	5,02	22,28
13.320	119,9	39,9	10	5,15	23,38
13.860	122,9	39,5	11	5,29	24,50
14.400	126,0	39,1	11	5,42	25,61
14.940	128,9	38,8	12	5,54	26,73
15.480	131,9	38,5	12	5,67	27,85
16.020	134,7	38,1	13	5,79	28,96
16.560	137,5	37,8	14	5,91	30,08
17.100	140,2	37,5	15	6,03	31,20
17.640	143,0	37,2	15	6,15	32,32

*Based on 90°C entering water temperature, 20°C water temperature drop, 13°C entering air temperature.

50 UC-(V)/UP-(V) 125 & 140 & 160 - Low Heat

Air Flow Rate	Capacity*	Air Outlet Dry Bulb Temperature	Air Pressure Drop	Water Flow Rate	Water Pressure Drop
m ³ /h	kW	°C	Pa	m ³ /h	kPa
13.680	114,5	38,0	23	4,92	8,65
14.472	118,2	37,4	26	5,08	9,15
15.264	121,9	36,9	28	5,24	9,65
16.056	125,3	36,3	31	5,39	10,15
16.848	128,8	35,8	33	5,54	10,65
17.640	132,1	35,4	36	5,68	11,14
18.432	135,4	34,9	39	5,82	11,64
19.224	138,5	34,5	42	5,96	12,12
20.016	141,6	34,1	45	6,09	12,61
20.808	144,6	33,8	48	6,22	13,09
21.600	147,5	33,4	51	6,34	13,57
22.392	150,4	33,1	55	6,47	14,05
23.184	153,2	32,7	58	6,59	14,53
23.976	155,9	32,4	62	6,70	15,00
24.768	158,6	32,1	65	6,82	15,47
25.560	161,2	31,8	69	6,93	15,93
26.352	163,8	31,6	72	7,04	16,40
27.144	166,3	31,3	76	7,15	16,86
27.936	168,8	31,0	80	7,26	17,32

*Based on 90°C entering water temperature, 20°C water temperature drop, 13°C entering air temperature.



50 UC-(V)/UP-(V) 125 & 140 & 160 - High Heat

Air Flow Rate m ³ /h	Capacity* kW	Air Outlet Dry Bulb Temperature °C	Air Pressure Drop Pa	Water Flow Rate m ³ /h	Water Pressure Drop kPa
13.680	172,5	50,7	42	7,42	11,47
14.472	178,8	49,9	47	7,69	12,19
15.264	185,0	49,2	51	7,96	12,94
16.056	190,9	48,5	56	8,21	13,66
16.848	196,8	47,9	60	8,46	14,41
17.640	202,4	47,3	65	8,70	15,13
18.432	208,0	46,7	70	8,94	15,88
19.224	213,3	46,2	76	9,17	16,61
20.016	218,6	45,6	81	9,40	17,35
20.808	223,7	45,1	87	9,62	18,08
21.600	228,8	44,6	93	9,84	18,82
22.392	233,6	44,2	99	10,05	19,54
23.184	238,5	43,7	105	10,26	20,28
23.976	243,2	43,3	111	10,46	21,00
24.768	247,9	42,9	117	10,66	21,73
25.560	252,3	42,5	124	10,85	22,45
26.352	256,8	42,1	130	11,04	23,18
27.144	261,2	41,7	137	11,23	23,90
27.936	265,5	41,4	144	11,42	24,62

*Based on 90°C entering water temperature, 20°C water temperature drop, 13°C entering air temperature.

50 UC-(V)/UP-(V) 190 & 220 - Low Heat

Air Flow Rate m ³ /h	Capacity* kW	Air Outlet Dry Bulb Temperature °C	Air Pressure Drop Pa	Water Flow Rate m ³ /h	Water Pressure Drop kPa
23.760	176,4	35,2	32	7,59	42,64
24.660	180,1	34,8	34	7,74	44,29
25.560	183,6	34,5	36	7,90	45,92
26.460	187,1	34,1	38	8,04	47,54
27.360	190,4	33,8	41	8,19	49,13
28.260	193,7	33,5	43	8,33	50,70
29.160	196,9	33,2	46	8,47	52,25
30.060	199,9	32,9	48	8,60	53,77
30.960	202,9	32,6	51	8,72	55,26
31.860	205,7	32,3	53	8,85	56,72
32.760	208,5	32,0	56	8,97	58,14
33.660	211,2	31,7	59	9,08	59,53
34.560	213,7	31,5	61	9,19	60,88
35.460	216,2	31,2	64	9,30	62,20
36.360	218,5	31,0	67	9,40	63,47
37.260	220,8	30,7	70	9,49	64,70
38.160	223,0	30,5	73	9,59	65,89
39.060	225,0	30,2	76	9,68	67,03
39.960	227,0	30,0	79	9,76	68,13

*Based on 90°C entering water temperature, 20°C water temperature drop, 13°C entering air temperature.

50 UC-(V)/UP-(V) 190 & 220 - High Heat

Air Flow Rate m ³ /h	Capacity* kW	Air Outlet Dry Bulb Temperature °C	Air Pressure Drop Pa	Water Flow Rate m ³ /h	Water Pressure Drop kPa
23.760	250,3	44,5	60	10,76	35,50
24.660	255,2	43,9	64	10,98	36,83
25.560	260,2	43,4	68	11,19	38,16
26.460	265,0	42,9	72	11,39	39,49
27.360	269,7	42,5	77	11,60	40,82
28.260	274,4	42,0	81	11,80	42,15
29.160	278,9	41,6	85	11,99	43,47
30.060	283,4	41,2	90	12,19	44,79
30.960	287,8	40,8	94	12,37	46,11
31.860	292,1	40,4	99	12,56	47,41
32.760	296,3	40,0	103	12,74	48,71
33.660	300,5	39,7	108	12,92	50,00
34.560	304,5	39,3	112	13,09	51,27
35.460	308,5	39,0	117	13,26	52,54
36.360	312,4	38,7	122	13,43	53,80
37.260	316,2	38,4	126	13,60	55,04
38.160	319,9	38,0	131	13,75	56,26
39.060	323,5	37,7	136	13,91	57,48
39.960	327,0	37,5	141	14,06	58,67

*Based on 90°C entering water temperature, 20°C water temperature drop, 13°C entering air temperature.



Hot Water Coil Correction Factors By Temperature

50 UC-(V)/UP-(V) 025 & 035 & 045 & 055

Water Temperature Drop (°C)	Entering Water Temperature (°C)	Entering Air Temperature (°C)										
		-20	-15	-10	-5	0	5	10	15	20	25	30
10	50	1,053	0,959	0,866	0,776	0,686	0,599	0,512	0,428	0,344	0,263	0,182
	60	1,232	1,136	1,041	0,949	0,857	0,768	0,680	0,594	0,508	0,425	0,343
	70	1,411	1,314	1,216	1,122	1,028	0,938	0,847	0,760	0,672	0,587	0,503
	80	1,591	1,491	1,392	1,296	1,200	1,108	1,016	0,926	0,837	0,750	0,664
	90	1,770	1,669	1,567	1,470	1,372	1,278	1,184	1,093	1,001	0,913	0,825
20	50	0,901	0,809	0,718	0,630	0,542	0,457	0,371	0,286	0,200	0,105	0,010
	60	1,084	0,990	0,897	0,807	0,717	0,630	0,542	0,457	0,371	0,281	0,192
	70	1,267	1,171	1,075	0,983	0,891	0,803	0,714	0,627	0,541	0,458	0,374
	80	1,449	1,351	1,253	1,159	1,066	0,975	0,884	0,796	0,708	0,623	0,538
	90	1,631	1,531	1,431	1,335	1,240	1,147	1,055	0,965	0,875	0,788	0,701

50 UC-(V)/UP-(V) 065 & 075 & 090 & 105

Water Temperature Drop (°C)	Entering Water Temperature (°C)	Entering Air Temperature (°C)										
		-20	-15	-10	-5	0	5	10	15	20	25	30
10	50	1,052	0,958	0,864	0,774	0,684	0,597	0,511	0,427	0,343	0,263	0,182
	60	1,231	1,135	1,039	0,947	0,855	0,766	0,677	0,592	0,506	0,423	0,341
	70	1,409	1,312	1,214	1,120	1,025	0,935	0,844	0,756	0,668	0,584	0,499
	80	1,588	1,489	1,389	1,293	1,197	1,104	1,011	0,921	0,832	0,745	0,658
	90	1,768	1,666	1,564	1,466	1,368	1,273	1,178	1,087	0,995	0,906	0,817
20	50	0,903	0,812	0,720	0,632	0,544	0,458	0,373	0,287	0,200	0,108	0,016
	60	1,086	0,992	0,898	0,808	0,718	0,631	0,544	0,457	0,371	0,283	0,195
	70	1,268	1,173	1,077	0,984	0,892	0,803	0,714	0,628	0,542	0,458	0,374
	80	1,450	1,352	1,254	1,160	1,066	0,974	0,883	0,795	0,707	0,622	0,536
	90	1,632	1,532	1,432	1,335	1,239	1,146	1,053	0,963	0,873	0,786	0,698

50 UC-(V)/UP-(V) 125 & 140 & 160 - Low Heat

Water Temperature Drop (°C)	Entering Water Temperature (°C)	Entering Air Temperature (°C)										
		-20	-15	-10	-5	0	5	10	15	20	25	30
10	50	1,055	0,959	0,864	0,772	0,679	0,590	0,501	0,414	0,328	0,245	0,162
	60	1,246	1,149	1,052	0,957	0,863	0,771	0,680	0,591	0,503	0,417	0,331
	70	1,437	1,338	1,239	1,143	1,047	0,953	0,859	0,768	0,677	0,589	0,501
	80	1,628	1,527	1,426	1,328	1,230	1,135	1,039	0,946	0,853	0,763	0,672
	90	1,818	1,715	1,613	1,513	1,413	1,316	1,219	1,124	1,029	0,937	0,844
20	50	0,853	0,761	0,670	0,581	0,493	0,407	0,322	0,230	0,138	0,073	0,009
	60	1,051	0,957	0,863	0,772	0,681	0,593	0,505	0,415	0,325	0,250	0,175
	70	1,249	1,152	1,056	0,962	0,869	0,778	0,688	0,600	0,512	0,426	0,341
	80	1,444	1,345	1,247	1,152	1,056	0,963	0,871	0,781	0,690	0,603	0,515
	90	1,639	1,538	1,438	1,341	1,243	1,149	1,054	0,962	0,869	0,779	0,689

50 UC-(V)/UP-(V) 190 & 220 - Low Heat

Water Temperature Drop (°C)	Entering Water Temperature (°C)	Entering Air Temperature (°C)										
		-20	-15	-10	-5	0	5	10	15	20	25	30
10	50	1,073	0,975	0,877	0,783	0,689	0,598	0,508	0,420	0,333	0,248	0,164
	60	1,264	1,164	1,064	0,968	0,871	0,778	0,685	0,596	0,506	0,420	0,333
	70	1,454	1,352	1,250	1,152	1,053	0,958	0,863	0,771	0,679	0,591	0,502
	80	1,645	1,541	1,436	1,336	1,235	1,138	1,041	0,947	0,853	0,762	0,671
	90	1,835	1,729	1,623	1,520	1,417	1,318	1,219	1,123	1,027	0,934	0,841
20	50	0,874	0,780	0,685	0,595	0,504	0,415	0,327	0,243	0,159	0,082	0,006
	60	1,071	0,975	0,878	0,784	0,691	0,600	0,510	0,423	0,336	0,255	0,173
	70	1,269	1,169	1,070	0,974	0,878	0,786	0,693	0,603	0,514	0,427	0,340
	80	1,464	1,362	1,261	1,162	1,064	0,970	0,875	0,783	0,691	0,602	0,514
	90	1,659	1,555	1,451	1,351	1,251	1,154	1,057	0,963	0,869	0,778	0,687

50 UC-(V)/UP-(V) 190 & 220 - High Heat

Water Temperature Drop (°C)	Entering Water Temperature (°C)	Entering Air Temperature (°C)										
		-20	-15	-10	-5	0	5	10	15	20	25	30
10	50	1,073	0,975	0,877	0,783	0,689	0,598	0,508	0,420	0,333	0,248	0,164
	60	1,264	1,164	1,064	0,968	0,871	0,778	0,685	0,596	0,506	0,420	0,333
	70	1,454	1,352	1,250	1,152	1,053	0,958	0,863	0,771	0,679	0,591	0,502
	80	1,645	1,541	1,436	1,336	1,235	1,138	1,041	0,947	0,853	0,762	0,671
	90	1,835	1,729	1,623	1,520	1,417	1,318	1,219	1,123	1,027	0,934	0,841
20	50	0,874	0,780	0,685	0,595	0,504	0,415	0,327	0,243	0,159	0,082	0,006
	60	1,071	0,975	0,878	0,784	0,691	0,600	0,510	0,423	0,336	0,255	0,173
	70	1,269	1,169	1,070	0,974	0,878	0,786	0,693	0,603	0,514	0,427	0,340
	80	1,464	1,362	1,261	1,162	1,064	0,970	0,875	0,783	0,691	0,602	0,514
	90	1,659	1,555	1,451	1,351	1,251	1,154	1,057	0,963	0,869	0,778	0,687



Hot Water Coil Correction Factors By Liquid

50 UC-(V)/UP-(V) 025 - 220

Ethylen Glycol (%)	Capacity Correction Factor	Water Pressure Drop Correction Factor
10	0,990	1,019
20	0,978	1,039
30	0,962	1,061
35	0,952	1,073

Propylen Glycol (%)	Capacity Correction Factor	Water Pressure Drop Correction Factor
10	0,980	1,032
20	0,954	1,070
30	0,924	1,112
35	0,908	1,134



Rotary Energy Recovery Module (ERM)

Physical DataE: Enthalpic type rotary heat exchanger; S: Sorption type rotary heat exchanger

ERM Model	Unit	ERM3.0 E	ERM5.0 E	ERM7.1 E	ERM9.1 E	ERM11.3 E	ERM14.3 E	ERM17.4 E	ERM23.5 E	ERM29.6 E
Opt 172		ERM3.0 E	ERM5.0 E	ERM7.1 E	ERM9.1 E	ERM11.3 E	ERM14.3 E	ERM17.4 E	ERM23.5 E	ERM29.6 E
Opt 174		ERM3.0 S	ERM5.0 S	ERM7.1 S	ERM9.1 S	ERM11.3 S	ERM14.3 S	ERM17.4 S	ERM23.5 S	ERM29.6 S
Weight										
Enthalpic (E)	kg	194	208	242	251	325	349	374	480	549
Sorption (S)	kg	195	210	245	255	330	355	382	490	560
Air Flow Rate										
Maximum	m ³ /h	3.500	5.700	7.300	9.200	14.200	17.560	17.560	23.800	29.000
Minimum	m ³ /h	800	1.350	1.700	2.150	2.650	3.300	4.200	5.600	6.650
Unit Thermal / Humidity Efficiency* for Enthalpic										
Maximum Air Flow Rate	%	67.4 / 48.2	67.4 / 48.2	67.5 / 48.3	67.5 / 48.3	67.5 / 48.3	67.5 / 48.3	67.5 / 48.3	67.5 / 48.3	49.4 / 5.6
Minimum Air Flow Rate	%	81.9 / 65.8	81.8 / 65.5	81.9 / 65.7	81.9 / 65.7	81.9 / 65.6	81.9 / 65.6	81.8 / 65.5	81.9 / 65.6	76.9 / 24.3
Unit Thermal / Humidity Efficiency* for Sorption										
Maximum Air Flow Rate	%	69.4 / 58.0	69.4 / 58.0	69.4 / 58.0	69.4 / 58.0	69.4 / 58.1	69.4 / 58.0	69.4 / 58.0	69.4 / 58.0	55.6 / 30.7
Minimum Air Flow Rate	%	82.3 / 91.7	82.2 / 91.3	82.3 / 91.6	82.2 / 91.5	82.2 / 91.4	82.3 / 91.6	82.2 / 91.3	82.2 / 91.4	79.5 / 77.3
Rooftop Model Compatibility										
025		x								
035			x							
045				x						
055					x					
065						x				
075							x			
090								x		
105									x	
125										x
140									x	
160										x
190										x
220										x
Energy Recovery Heat Exchanger										
Wheel Diameter	mm	715	915	1,040	1,165	1,290	1,450	1,615	1,875	2,075
Motor Speed										
E	rpm					10				
S	rpm					20				
Motor IP Class						IP 54				
Filter										
Filter Class (ISO 16890)		ISO Coarse 65% Filter (G4 Cardboard Frame Filter)								
Quantity	pcs	2	2	2	2	3	3	3	4	6
Filter Size	mm x mm x mm	565 x 685 x 50	565 x 685 x 50	620 x 800 x 50	620 x 800 x 50	535 x 940 x 50	535 x 940 x 50	565 x 940 x 50	1060 x 595 x 50	715 x 630 x 50
Operating Limits										
Maximum Outdoor Temperature	°C					+52				
Minimum Outdoor Temperature	°C					-20				
Dimensions										
Width	mm	1,200	1,200	1,320	1,320	1,685	1,685	1,770	2,070	2,220
Length (With Fresh Air Hood)	mm	700 (1.040)	700 (1.040)	700 (1.115)	700 (1.115)	700 (1.205)	700 (1.205)	700 (1.205)	1000 (1.585)	1,100 (1.740)
Height	mm	1,485	1,485	1,715	1,715	2,000	2,000	2,000	2,153	2,310

*Thermal efficiency of supply air @ -10 °C outdoor air and @ 21 °C / 50% RH return air.

Physical Data

E: Enthalpic type rotary heat exchanger; S: Sorption type rotary heat exchanger

ERM Model	Unit	ERM5.0 E	ERM7.0 E	ERM9.1 E	ERM11.2 E	ERM13.3 E	ERM14.3 E	ERM17.4 E	ERM23.5 E	ERM28.6 E	ERM40.7 E
Opt 176		ERM5.0 E	ERM7.0 E	ERM9.1 E	ERM11.2 E	ERM13.3 E	ERM14.3 E	ERM17.4 E	ERM23.5 E	ERM28.6 E	ERM40.7 E
Opt 177		ERM5.0 S	ERM7.0 S	ERM9.1 S	ERM11.2 S	ERM13.3 S	ERM14.3 S	ERM17.4 S	ERM23.5 S	ERM28.6 S	ERM40.7 S
Weight											
Enthalpic (E)	kg	208	217	251	285	345	349	374	480	563	725
Sorption (S)	kg	210	220	255	290	351	355	382	490	575	740
Air Flow Rate											
Maximum	m ³ /h	5.700	7.300	9.200	11.300	13.500	14.200	17.560	23.800	27.930	40450
Minimum	m ³ /h	1.350	1.700	2.150	2.650	3.200	3.300	4.200	5.600	6.600	9250
Unit Thermal / Humidity Efficiency* for Enthalpic											
Maximum Air Flow Rate	%	67.4 / 48.2	67.5 / 48.3	67.5 / 48.3	67.5 / 48.3	67.5 / 48.3	67.5 / 48.3	67.5 / 48.3	67.5 / 48.3	67.5 / 48.3	49.4 / 5.6
Minimum Air Flow Rate	%	81.8 / 65.5	81.9 / 65.7	81.9 / 65.7	81.9 / 65.6	81.9 / 65.6	81.9 / 65.6	81.8 / 65.5	81.9 / 65.6	81.9 / 65.6	76.9 / 24.3
Unit Thermal / Humidity Efficiency* for Sorption											
Maximum Air Flow Rate	%	69.4 / 58.0	69.4 / 58.0	69.4 / 58.0	69.4 / 58.0	69.4 / 58.1	69.4 / 58.0	69.4 / 58.0	69.4 / 58.0	69.4 / 58.0	55.6 / 30.6
Minimum Air Flow Rate	%	82.2 / 91.3	82.3 / 91.6	82.2 / 91.5	82.2 / 91.4	82.2 / 91.4	82.3 / 91.6	82.2 / 91.3	82.2 / 91.4	82.2 / 91.4	79.5 / 77.3
Rooftop Model Compatibility											
025		x									
035			x								
045				x							
055			x		x						
065						x					
075							x				
090								x			
105									x		
125										x	
140											x
160											x
190											x
220											x
Energy Recovery Heat Exchanger											
Wheel Diameter	mm	915	1,040	1,165	1,290	1,415	1,450	1,615	1,875	2,030	2450
Motor Speed											
E	rpm					10					
S	rpm					20					
Motor IP Class						IP 54					
Filter											
Filter Class (ISO 16890)		ISO Coarse 66% Filter (G4 Cardboard Frame Filter)									
Quantity	pcs	2	2	2	3	3	3	3	4	6	6
Filter Size	mm x mm x mm	565 x 685 x 50	565 x 685 x 50	620 x 800 x 50	456 x 800 x 50	535 x 940 x 50	535 x 940 x 50	565 x 940 x 50	1060 x 595 x 50	715 x 630 x 50	830 x 780 x 50
Operating Limits											
Maximum Outdoor Temperature	°C					+52					
Minimum Outdoor Temperature	°C					-20					
Dimensions											
Width	mm	1,200	1,200	1,320	1,440	1,685	1,685	1,770	2,070	2,220	2,560
Length (With Fresh Air Hood)	mm	700 (1.040)	700 (1.040)	700 (1.115)	700 (1.115)	700 (1.205)	700 (1.205)	700 (1.205)	1000 (1.585)	1,100 (1.740)	1360(2090)
Height	mm	1,485	1,485	1,715	1,715	2,000	2,000	2,000	2,153	2,310	2,655

*Thermal efficiency of supply air @ -10 °C outdoor air and @ 21 °C / 50% RH return air.



Electrical Data

E: Enthalpic type rotary heat exchanger; S: Sorption type rotary heat exchanger

ERM Model	Unit									
Opt 172		ERM3.0 E	ERM5.0 E	ERM7.1 E	ERM9.1 E	ERM11.3 E	ERM14.3 E	ERM17.4 E	ERM23.5 E	ERM29.6 E
Opt 174		ERM3.0 S	ERM5.0 S	ERM7.1 S	ERM9.1 S	ERM11.3 S	ERM14.3 S	ERM17.4 S	ERM23.5 S	ERM29.6 S
Power Circuit										
Nominal Power Supply	V-ph-Hz	400-3-50								
Voltage Range	V	360-440								
Control Circuit Supply		24 V, via Internal Transformer								
Maximum Input Power	W	90	90	90	90	90	180	180	180	220
Maximum Input Current	A	0,37	0,37	0,37	0,37	0,37	0,60	0,60	0,60	2,00
Maximum Supply Cable Size	mm ²	1,50	1,50	1,50	1,50	1,50	1,50	1,50	1,50	1,50

Electrical Data

ERM Model	Unit										
Opt 176		ERM5.0 E	ERM7.0 E	ERM9.1 E	ERM11.2 E	ERM13.3 E	ERM14.3 E	ERM17.4 E	ERM23.5 E	ERM28.6 E	ERM40.7 E
Opt 177		ERM5.0 S	ERM7.0 S	ERM9.1 S	ERM11.2 S	ERM13.3 S	ERM14.3 S	ERM17.4 S	ERM23.5 S	ERM28.6 S	ERM40.7 S
Power Circuit											
Nominal Power Supply	V-ph-Hz	400-3-50									
Voltage Range	V	360-440									
Control Circuit Supply		24 V, via Internal Transformer									
Maximum Input Power	W	90	90	90	90	90	180	180	180	370	220
Maximum Input Current	A	0,37	0,37	0,37	0,37	0,37	0,60	0,60	0,60	1,11	2,00
Maximum Supply Cable Size	mm ²	1,50	1,50	1,50	1,50	1,50	1,50	1,50	1,50	1,50	1,50

DIMENSIONS FOR ERM

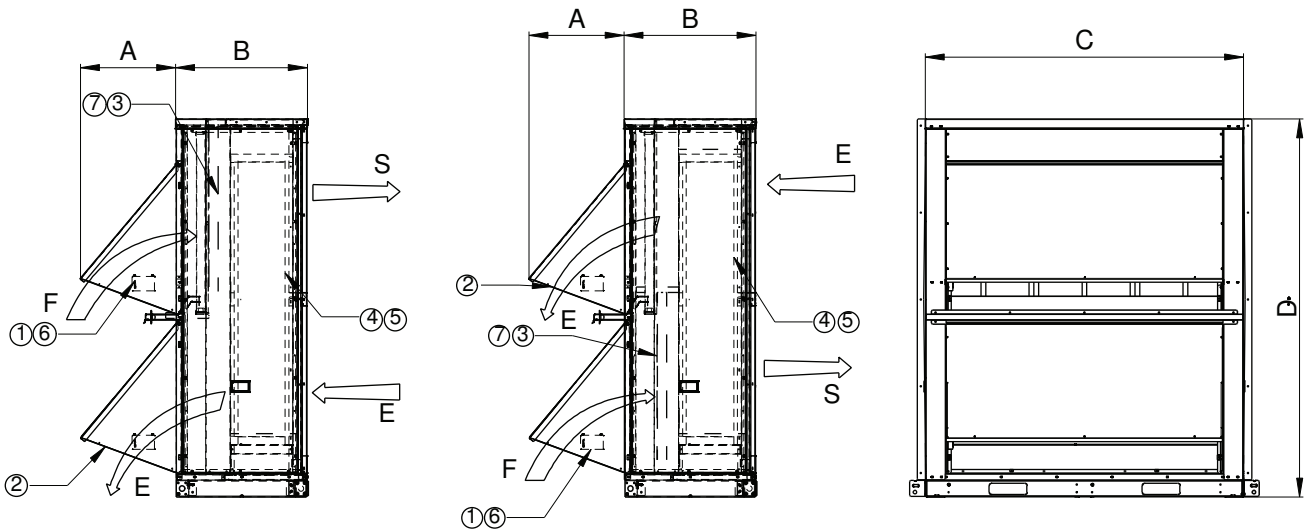

Unit size		A	B	C	D
ERM 3.0 E/S	mm	339	697.5	1197	1485
ERM 5.0 E/S	mm	339	697.5	1197	1485
ERM 7.0 E/S	mm	339	697.5	1197	1485
ERM 7.1 E/S	mm	413	697.5	1317	1715
ERM 9.1 E/S	mm	413	697.5	1317	1715
ERM 11.2 E/S	mm	414	697.5	1440	1715
ERM 11.3 E/S	mm	505	697.5	1684	2000
ERM 13.3 E/S	mm	505	697.5	1684	2000
ERM 14.3 E/S	mm	505	697.5	1684	2000
ERM 17.4 E/S	mm	505	697.5	1770	2000
ERM 23.5 E/S	mm	585	997.5	2070	2153
ERM 28.6 E/S	mm	638	1097.5	2225	2310
ERM 29.6 E/S	mm	638	1097.5	2225	2310
ERM 40.7 E/S	mm	729	1357.5	2570	2655

- ① Fresh air hood
- ② Exhaust air hood
- ③ Filter
- ④ Energy recovery wheel
- ⑤ Motion sensor
- ⑥ Enthalpy sensor (OPT)
- ⑦ Dirty filter switch (OPT)
- ⓕ Fresh air
- ⓔ Exhaust air
- Ⓢ Supply air

Services clearances (mm)

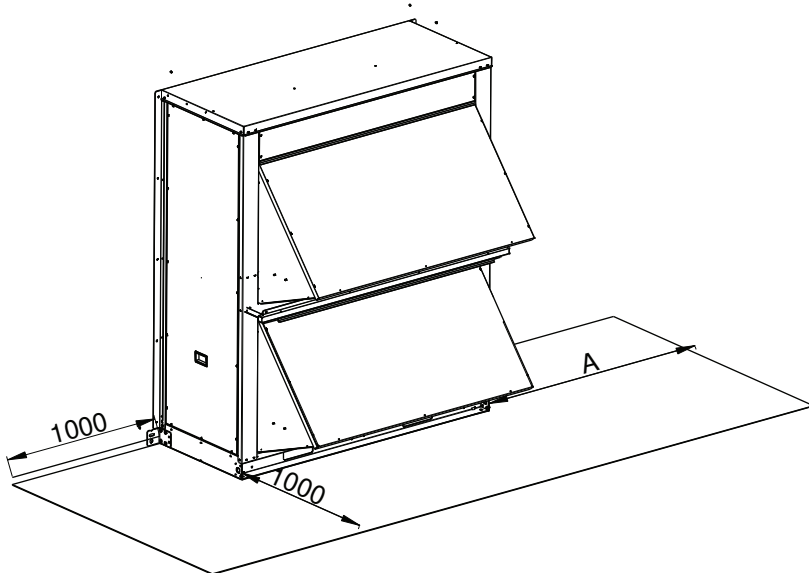

Unit size		A
ERM 3.0 E/S	mm	900
ERM 5.0 E/S	mm	1000
ERM 7.0 E/S	mm	1200
ERM 7.1 E/S	mm	1200
ERM 9.1 E/S	mm	1300
ERM 11.2 E/S	mm	1400
ERM 11.3 E/S	mm	1400
ERM 13.3 E/S	mm	1500
ERM 14.3 E/S	mm	1600
ERM 17.4 E/S	mm	1700
ERM 23.5 E/S	mm	2070
ERM 28.6 E/S	mm	2225
ERM 29.6 E/S	mm	2225
ERM 40.7 E/S	mm	2570

STEP 1: RECIRCULATION MODE

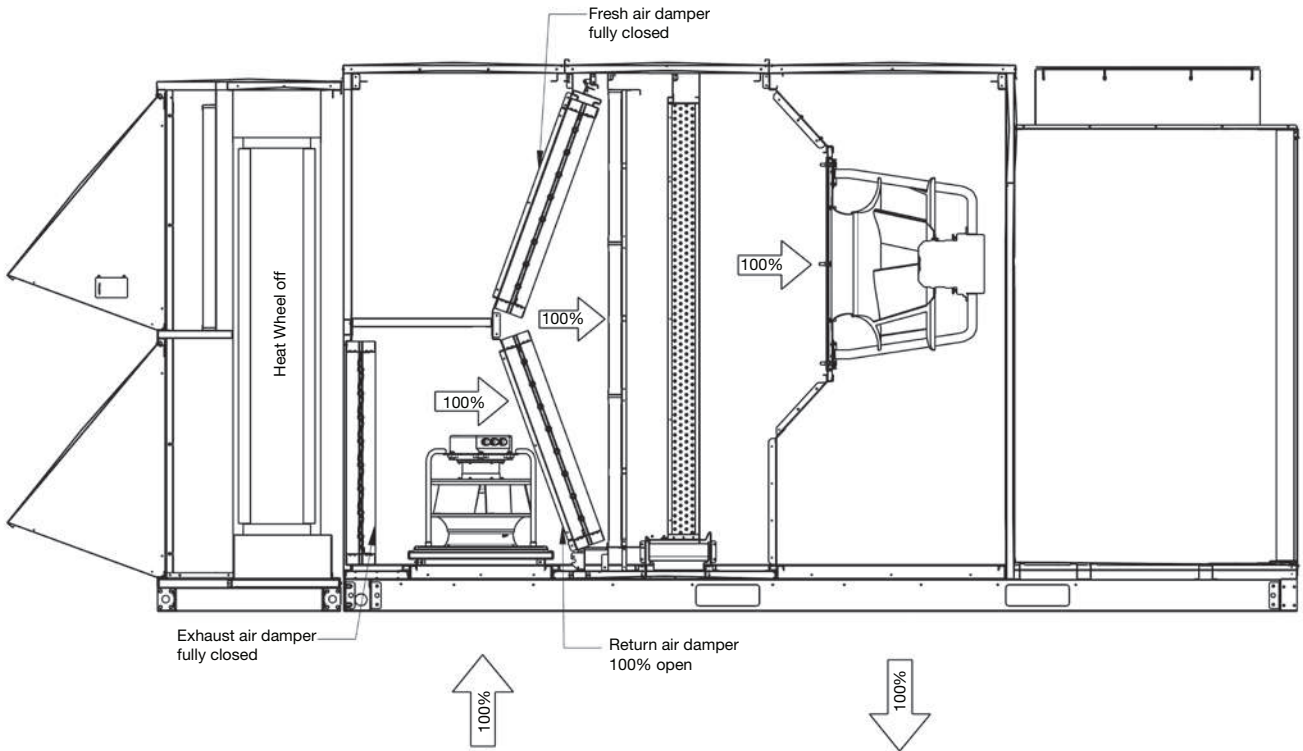

STEP 2: ENERGY RECOVERY MODE

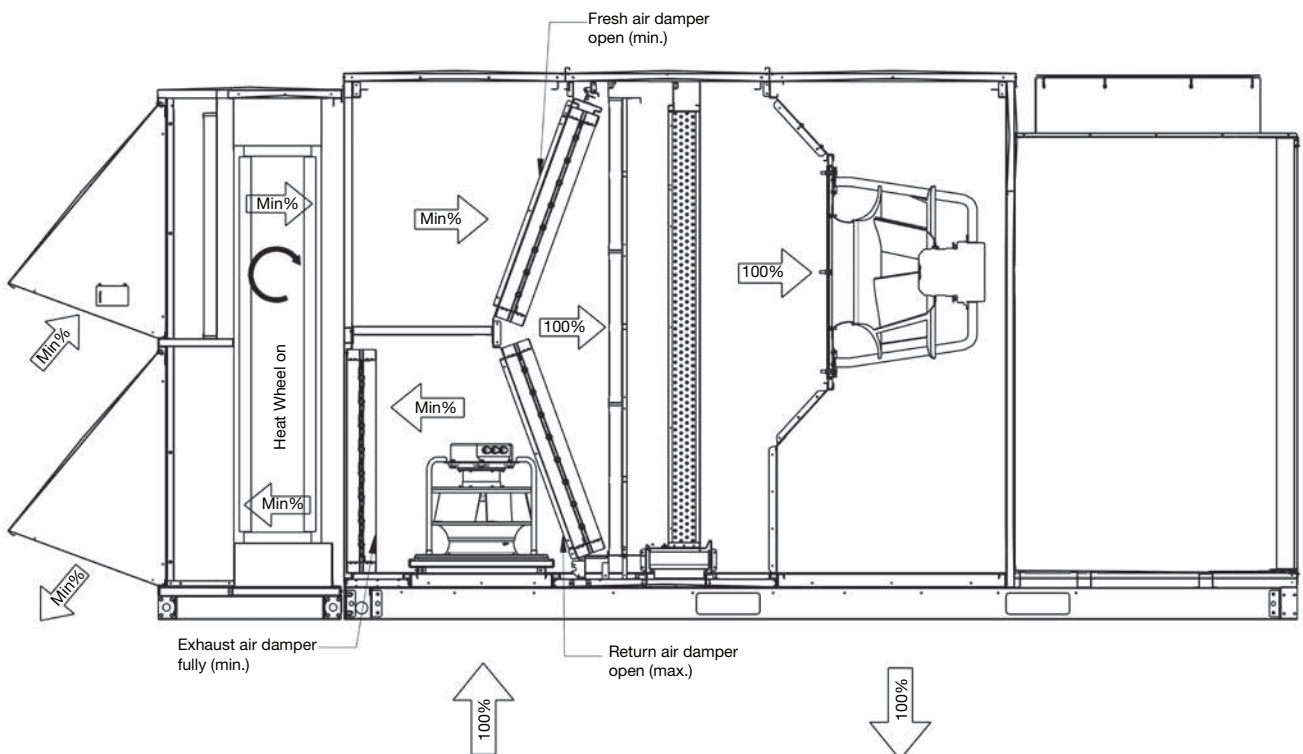



STEP 3: FREE-COOLING MODE

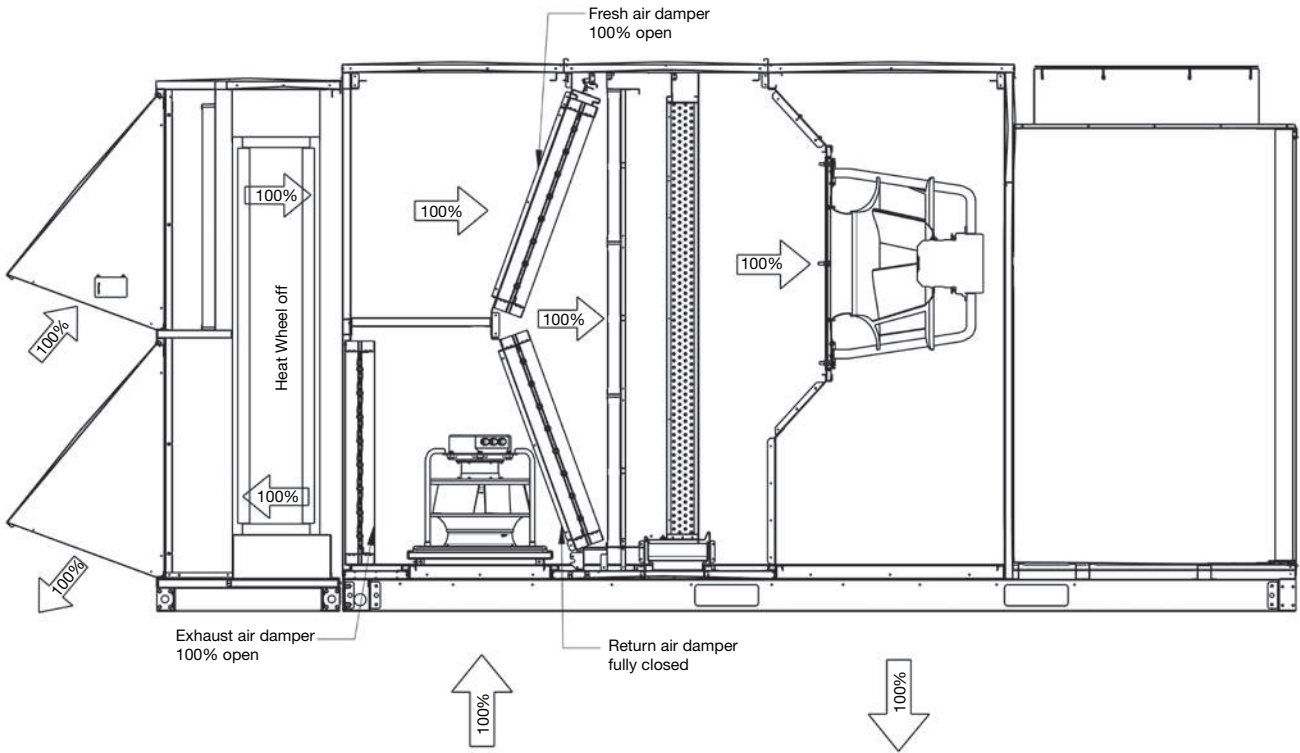



THERMODYNAMIC ENERGY RECOVERY (THR)

Mode	Wheel	Indoor Fan	Return Fan	Fresh Air Damper	Return Air Damper	Exhaust Air Damper
1 - Recirculation	Off	On	Off/On	100% Closed	100% Open	100% Closed
2 - Energy Recovery	On	On	Off/On	Minimum	Maximum	Minimum
3 - Free Cooling	Off	On	On	100% Open	100% Closed	100% Open

Unit Model		Unit	025	035	045	055	065	075	090	105	125	140	160
Nominal Air Flow Rate		m ³ /h	4.205	5.886	7.568	9.250	10.463	11.533	12.500	14.500	19.375	20.981	23.274
THR Circuit Compressor Characteristics	Type	Scroll											
	No of Circuit / No of Compressor	1 / 1											
	Oil Type	PVE										POE	
	Oil Volume	l	1,06		1,57				3,30				
	Maximum Input Current	A	12		15		19		31				
Refrigerant Charge (R410A)		kg	3,6		4,6		5,4		6,6				

Cooling Operation			Heat Pump Operation		
Zone	Air Temperature		Zone	Air Temperature	
	Dry Bulb	Wet Bulb		Dry Bulb	Wet Bulb
Indoor			Indoor		
Maximum	+35 °C	+24 °C	Maximum	+27 °C	
Minimum	+15 °C	+13 °C	Minimum	+10 °C	



PRODUCT GUIDE SPECIFICATION

General Description

- A rooftop is a unitary system installed outdoors and provides air conditioning of indoor air through ducts with the ability to supply heating, cooling and ventilation in one concise unit.

Standard / Certificate / Test

- Rooftops shall confirm the following European Directives and carry CE sign for their requirements. Also, these units shall confirm EU 2016/2281 EcoDesign requirements, which is valid in Europe from 2018.
- Units shall be manufactured in a facility having ISO 9001, ISO 14001, ISO 27001, ISO 50001, OHSAS 18001 and SA 8000 certificates.
- Units shall have Eurovent, CE, EAC and Domestic Goods certificates.
- Filters utilized in units shall have fire and test certificates.
- Before units are delivered from the factory, run tests consisting of safety, electric and functional tests, including refrigerant leakage test shall be performed.
- Run test reports shall also be delivered together with the unit.
- Rooftop manufacturer's factory should have a psychometrics test laboratory which performance tests are performed.
- Customers shall have the right to make an application of performance witness test for the unit subject to payment of test fee and scheduling their visit.

Operating Temperature Range

- Rooftops shall be capable to operate thermodynamically at ambient temperatures from -10 °C to +48 °C for heating and cooling at full load.
- If heating is not supplied thermodynamically and auxiliary heating options are being utilized instead, units shall operate down to -20 °C in winter.

Casing

- The indoor part of the unit shall have double skin sandwich panels having 30 mm thickness to minimize heat transfer between conditioned air and ambient air.
- Sandwich panels shall have A1 flame-retardant class with a minimum density of 30 kg/m³ glasswool insulation inside.
- Sandwich panels shall be made of 160 gr/m² zinc coated galvanized steel sheets.

- Outer panel sheet shall be thermoset powder coated and durable to 500 hours of salt spray test.
- All panels shall be removable for easy servicing.
- Risk of galvanic corrosion on the construction of the unit and fittings is minimum and warranted 2 years.

Filter

- G4 (ISO Coarse 65% Filter) type panel filter shall be used before indoor unit coil.
- Filter shall have 2 sections of minimum 50 mm each in a slide.
- M1 fire-retardant class, metal framed G4 (ISO Coarse 65% filter) type panel filter shall be used before indoor unit coil. (Optional)
- M1 fire-retardant class, metal framed F7 (ISO ePM1 55% filter) type panel filter shall be used before indoor unit coil. (Optional)
- M1 fire-retardant class, metal framed M6 + F7 (ISO ePM10 75% + ISO ePM1 55% filter) type panel filters shall be used before indoor unit coil. (Optional)
- M1 fire-retardant class, metal framed G4 + F7 (ISO Coarse 65% + ISO ePM1 55% filter) type panel filters shall be used before indoor unit coil. (Optional)
- M1 fire-retardant class, metal framed F7 + F9 (ISO ePM1 55% + ISO ePM1 80% filter) type panel filters shall be used before indoor unit coil. (Optional)

Coil

- Coils shall be formed by aluminium fins over internal grooved copper pipe.
- All coils shall be tested against leakage in a water pool under 45 bar pressurized air after manufacturing.
- Aluminium fins of indoor unit coils shall be covered by polyurethane for improved UV and corrosion resistance. (Optional)
- Aluminium fins of outdoor unit coils shall be covered by polyurethane for improved UV and corrosion resistance. (Optional)

Drain Pan

- A sloped drain pan made of minimum 304 grade stainless steel that can be dismantled through a sliding mechanism for easy servicing, with an insulated bottom shall be used under cooling coil.
- Asiphon with ball will be supplied by the manufacturer together with the unit to drain the water accumulated in drain pan.

Cooling Circuit

- Scroll compressors and R410A refrigerant shall be used in cooling circuit.
- For double circuit, two standard compressors for each circuit (total 4 standard compressors) and for single circuit one inverter compressor which equipped with rubber support and crankcase heater, shall be used.
- Unit shall be equipped with an oil sight glass, filter drier, pressure and temperature sensors, high pressure switch in each cooling circuit and electronic expansion valve.
- For double circuit units, coils of each circuit shall be interlaced for effectively utilization from the surfaces of evaporator coils when one cooling circuit of the unit is off.
- During transportation, compressor anchoring units shall be used (to be removed on site after transportation) to prevent damage on copper piping on the cooling circuit.

Defrost

- For double circuit heat pump units, when outdoor temperature is caused freezing on the outdoor coil, one circuit shall be work in cooling mode in order to defrost on the outdoor coil and other circuit shall be work in heating mode to approach optimum indoor temperature.
- To prevent ice accumulation on the base of outdoor unit coil, base of coil shall be sloped for easy drainage of water and an electric heater shall be installed on the base.

Efficiency

- All units shall have A class efficiency calculated at full load according to EN14511-2018 standard both in cooling and in heating mode.
- According to EcoDesign 2016/2281 Directive, all units shall have minimum 3.53 and 3.20 seasonal efficiencies in heating and cooling mode respectively confirming ERP 2021 standards.

Supply Fan

- Fan(s) to be used on supply side shall be EC plug type with IE4 motor efficiency class, IP54 protection class and minimum B insulation class.
- Monitoring and adjustments of air flow rate of these fans could be performed over the controller.
- Fans shall be sliding and could be pulled outwards through a guide for easy servicing.

- Operation mode of the fans could be adjustable over the controller as constant air volume (CAV) for operating without being influenced by duct pressure losses on critical line or variable air volume (VAV) considering indoor temperature and efficiency.
- The unit shall be equipped with a pressure sensor which shall stop the unit and give an alarm in case of a failure at supply fans of the unit.

Condenser Fan

- Condenser fans which are direct driven axial type shall be equipped with fan protection grill made of composite material resistant to corrosion.
- Fan motors shall be three phased, double speed and have minimum IP54 protection class and minimum B insulation class with overload protection.

Sensor

- For controlling temperature conditions of the room, outdoor, supply duct and room (or return duct) temperature sensors shall be provided together with the unit as standard.

Economizer (Optional)

- Fresh air and return dampers which equipped with spring return motors shall automatically optimize fresh air ratio according to outdoor air condition by taken input from sensors to approach efficient running. (100% fresh air = free cooling)
- Damper frames and blades shall be made of aluminium material and damper leakage class shall be minimum Class-2.
- Economizer shall be controlled by comparing the values of outdoor and indoor temperature sensors. (thermostatic control) (Optional)
- Economizer shall be controlled by comparing the values of outdoor and indoor temperature sensors and fresh air enthalpy sensors. (enthalpy control) (Optional)

Documentation

- An operation and installation manual shall be delivered inside the unit.
- Documents such as catalogue, EcoDesign information booklet, operation and installation manual, spare part list with exploded view, dimensional diagrams, wiring diagrams of the unit shall be accessible over a public website.

Handling / Transportation

- For easy handling on site, base of the unit shall have both spaces for entry of forks of a forklift and holes for lifting ropes.



- Units shall be wrapped by nylon for protection against outdoor ambient conditions during transportation and storage.

Duct Connection

- For making duct connections from the requested direction, units shall be delivered from the manufacturer to enable bottom, top and also side connection through a plenum both for supply and return side subject to information from the customer is received.

Control Panel / Human Machine Interface (HMI)

- Cables in the panel shall be colour coded and enumerated.
- The enclosure of the rooftop unit shall be fitted with IP68 protection class unions for all cable inputs and outputs.
- Each unit will have a permanent memory, a microprocessor controlled LCD display with a touch-sensitive 4,3 inch coloured screen which can be controlled by the unit to reach all parameters as standard for ease of use.
- This HMI shall be in IP65 protection class and have a cover to protect it from external impacts.
- Controller of the unit shall be accessible remotely through an Ethernet cable connected to the unit over the Internet, and an alarm on the unit shall be sent to a predetermined e-mail address.
- Various functions such as weekly/daily/hourly scheduling, control over two indoor sensors, preventing thermal shocks, master/slave control up to 6 units, night operation mode, purge mode and smart start shall be adjusted from the HMI according to user requirements.

Barometric Exhaust (Optional)

- Unit shall be equipped with barometric exhaust option at exhaust side of the unit made of aluminium blades, closing by gravity, protecting exhaust side from rainwater and enabling discharging of excessive positive pressure.

Power Exhaust Fan (Optional)

- An axial exhaust fan shall be equipped on exhaust side of the unit to enable excessive positive pressure when fresh air rate exceeds a certain value.

Return Fan (Optional)

- Fan(s) to be used on return side shall be EC plug type with IE4 motor efficiency class, IP54 protection class and minimum B insulation class to compensate the pressure at return duct.

- Monitoring and adjustments of air flow rate of these fans could be performed over the controller.
- Fans shall be sliding and could be pulled outwards through a guide for easy servicing.

Building Pressure Control (Optional)

- Through a pressure sensor that shall be provided by the manufacturer and utilized on site, pressure inside the building shall be adjusted over the controller and maintained at desired positive or negative value thanks to supply and return fans.

Electric Pre-Heater (Optional)

- Electric pre-heater shall be used to pre-heat fresh air when outdoor temperature drops below 10 °C or when system need additional heating requirement. (Cooling Only)
- Electric pre-heater shall be used to pre-heat fresh air when outdoor temperature drops below -10 °C or when system need additional heating requirement. (Heat Pump)

Electric Heater (Optional)

- The unit shall be equipped with a multi stage electric heater installed and tested at the factory.
- Electric heater shall have a total of four protection temperature switches which two of them can be reset manually and the other two can be reset automatically.
- Electric heaters shall be switched on automatically in defrost operation mode.

Hot Water Coil (Optional)

- The unit shall be equipped with a proportional hot water coil with 3-way valve installed and tested at the factory.
- Hot water coil shall be switched on automatically in defrost operation mode.
- For servicing, hot water coil shall be positioned with shut off valves.
- Opening of 3-way valve shall be adjusted according to supply temperature and 100% modulated (0-10 V) control shall be achieved.
- A frost protection thermostat shall be installed on hot water coil and according to the signal from this thermostat 3-way valve shall be opened automatically and all the water shall be circulated from the coil.

Natural Gas Heater (Optional)

- A condensing type, high efficient natural gas burner with 0 CO emission and low NOx emission (<30

ppm – Class-5) according to ERP directives shall be installed to the unit.

- Capacity control of natural gas heater shall be proportional with a 0-10 V signal between 25-100% range.
- Combustion chamber and all the heat exchangers shall be made of minimum AISI 441 stainless steel for longer service life.
- For safety reasons, natural gas heater shall be equipped with a manual reset safety thermostat, ignition and flame detecting electrodes, flame ionization control device and electronic ignition device for the burner.
- For gas opening transactions of natural gas devices, models of units with natural gas option shall be listed in approved products on Gazmer website.
- Smoke which is extracted by flue, shall not be mixtured with supply air.

Rotary Energy Recovery (Optional)

- For utilization of the energy of return air, rotary energy recovery which has Eurovent certificate, shall be used in the units.
- The module which the rotary energy recovery system is in shall be delivered separately from the factory and connected directly to the unit with connection apparatus supplied by the manufacturer on site without connecting ducts.
- The section between the rotary and the unit on fresh air side shall be 30 mm double wall insulated.
- G4 filter shall be installed on fresh air inlet for protecting the wheel.

Thermodynamic Energy Recovery (Optional)

- For utilizing the energy of return air, units shall be equipped with an additional cooling circuit with heat pump consisting of two DX coils, one at exhaust air side and the other in front of evaporator coil, a compressor and an expansion valve.
- Thermodynamic energy recovery cycle could be operated from 20% to 100% fresh air range.

Safety (Optional)

- The unit shall be equipped with a fire thermostat which shall stop the unit and give an alarm when return air temperature exceeds a predetermined value.
- The unit shall be equipped with a differential pressure switch which shall stop the unit and give an alarm

when pressure loss in the filters reaches a predetermined value.

- The unit shall be equipped with a smoke detector which shall stop the unit and give an alarm when sensing smoke inside the return duct.

Building Management System Communication (Optional)

- The unit controller shall offer BACnet IP protocol for communication with building management system.
- The unit controller shall offer Modbus TCP/IP protocol for communication with building management system.
- The unit controller shall offer Modbus RTU protocol for communication with building management system.

Compressor Insulation (Optional)

- Insulation shall be applied to compressor jackets to prevent freezing of the oil inside the compressor.

Roofcurb (Optional)

- A insulated roofcurb that is capable to bear the weight of the unit shall be installed to be utilized as a base between the unit and air duct and therefore facilitating installation.

Room Thermostat (Optional)

- A programmable room thermostat with an LCD display shall be provided to control the unit from room. (on/off, temperature control, mode selection, etc.).

Zone Controller (Optional)

- Zone controller with LCD display shall allow the unit to be controlled from the room. It allows all functions including on / off, alarm display & reset, user, service & factory configuration, setpoint setting, etc.)

Leak Detection (Optional)

- Leak detection shall be used to detect refrigerant leak, located after the indoor coil, before the indoor fan of the unit, to give an alarm and unit to shut down.

Dirty Filter Detection (Optional)

- Dirty filter detection shall be controlled from the SmartVu control via the input from the differential pressure switch checking the pressure drop across the filter.



CO₂ Sensor (Optional)

- The indoor air quality shall be provided by adjusting economizer dampers with output from CO₂ sensor which is located on the room

Compressor Soft Starter (Optional)

- Softstarter shall be used to expand lifespan of motors by protecting them from intense current.

Energy Meter (Optional)

- The energy meter shall be used to measure and display minimum, maximum and total current, voltage and frequency for each phase and active & reactive power and power factor and total active & reactive energy consumption.

Outdoor Coil Protection Grill (Optional)

- Outdoor coil protection grill shall be used to prevent damage on outdoor coil fins.



Order No: 13011. 12.2019. Supersedes Order No: 13011. 12.2018
Manufacturer reserves the right to change any product specifications without notice.

ALARKO



**ALARKO CARRIER
SANAYİ VE TİCARET A.Ş.**



GOSB-Gebze Organize Sanayi Bölgesi Ş. Bilgisu Cad. Gebze 41480 KOCAELİ / TURKEY
Tel: +90 (262) 648 60 00 **Faks:** +90 (262) 648 61 01



www.alarko-carrier.com.tr

e-mail: info@alarko-carrier.com.tr